



OCC *Outdoors*

Mop & Broom Holder

Cleaning & Maintenance Instructions

Products and Techniques to Avoid

To prevent damage to the stainless steel, powder-coated finish, or rubber grip

DO NOT USE:

- x Chlorine bleach or any cleaner containing chlorides
- x Oven cleaners or harsh chemical solvents
- x Petroleum-based products (WD-40, Goo Gone, mineral spirits)
- x Acetone, lacquer thinner, or other strong solvents
- x Steel wool, steel brushes, or abrasive pads
- x Abrasive powdered cleansers
- x Gritty or hard water that may leave stains

These materials can cause corrosion, discoloration, finish degradation, or rubber deterioration.

Approved Cleaning Methods

The stainless-steel surfaces, powder-coated steel components, and rubber grip can all be

SAFELY CLEANED using the following methods:

- ✓ Warm water and mild dish soap applied with a soft cloth or nylon brush
- ✓ Isopropyl alcohol (70-90%) for removing oils, fingerprints, or sticky residue
- ✓ Water-based, non-abrasive cleaners (e.g., Simple Green)
- ✓ Light use of a melamine sponge (Magic Eraser) for scuffs on rubber or steel
- ✓ After cleaning, rinse with clean water and dry thoroughly to prevent spotting or streaking

These methods are safe for all three materials and will not damage the finish or the rubber grip.

General Maintenance Recommendations

- Wipe stainless-steel and powder-coated surfaces regularly with a damp, soapy cloth, followed by a clean water rinse and a dry towel
- Always wipe stainless steel in the direction of the grain
- For heavier soil on metal surfaces, use a nylon scrubbing pad with mild detergent
- For stubborn stainless-steel stains, a baking-soda paste or undiluted vinegar may be used on the steel only; rinse and dry afterward
- For stainless steel only: Apply a non-abrasive stainless-steel polish periodically to maintain appearance. Suitable products include 3M Professional Grade, Bar Keeper's Friend, Cerama Bryte, Sprayway, and Weiman. Always apply polish in the direction of the grain and test in a hidden area first before applying to visible surfaces.

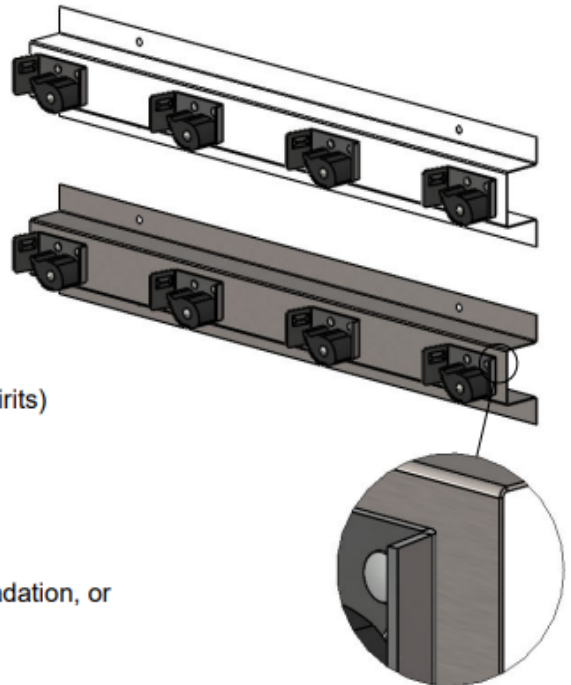

DIRECTION OF GRAIN
(LENGTHWISE)