

6 Foot Cambridge Park Bench w/ Arms

For Fastener Pack
(FP-CB6BA-CU-01)

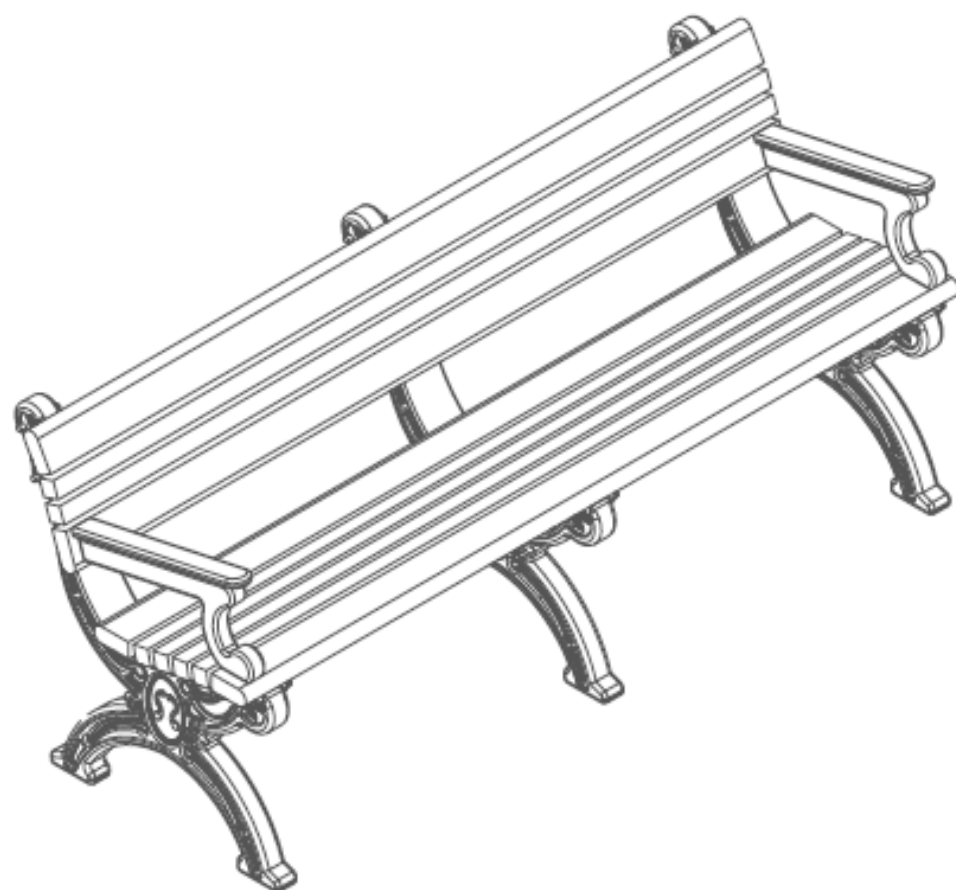

Congratulations !!

You have just purchased the finest recycled plastic
park bench available. Enjoy !!!

Before assembly, please make sure all components are included.

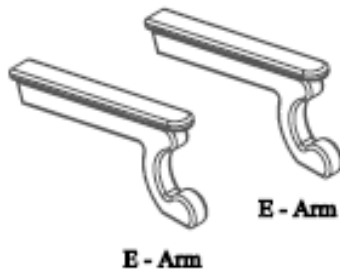

(2) - Two Arms
BSA-CBA-A-01



(1) - One Fastener Pack
FP-CB6BA-CU-01

FP - Fastener Pack

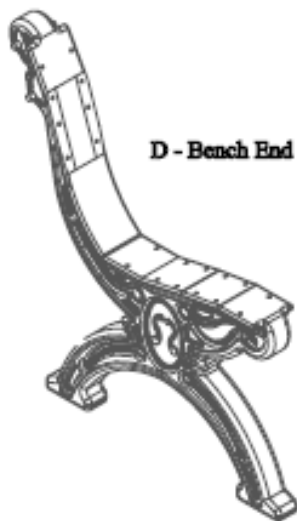

D - Bench End

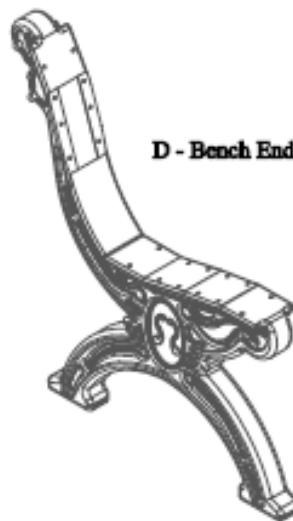

D - Bench End

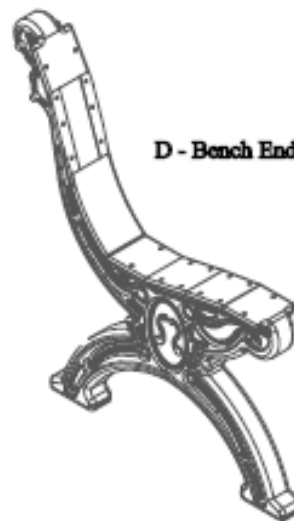

D - Bench End

(3) - Three Bench Ends
PS-CBBE-A-01

. .	A - Bull Nose Bench Board
. .	A - Bull Nose Bench Board

(2) - Two Bull Nose
Bench Boards
BP-CB6B-A-01

. .	B - Bench Board
. .	B - Bench Board
. .	B - Bench Board
. .	B - Bench Board
. .	B - Bench Board
. .	B - Bench Board

(6) - Six Bench Boards
BP-CB6B-B-01

. .	C - Bull Nose Bench Board w/ Arm Holes
. .	C - Bull Nose Bench Board w/ Arm Holes

(2) - Two Bull Nose
Bench Boards
w/ Arm Holes
BP-CB6BA-A-01

FS-CB6BA-CAP-01

Before assembly, please make sure all fasteners are included.

56 - #12 x 1 1/2" Pan Head Phillips Screw



4 - 1/4" x 3" Hex Head Lag Bolt



4 - 1/4" Flat Washer



Also needed for this assembly will be the following materials:

1 - #3 Phillips Drive Bit

1 - 7/16" Socket Wrench

Fig #1:

In order to make the assembly of this Cambridge Bench easier while going through the assembly process the board positions are numbered and will be referenced in later steps.

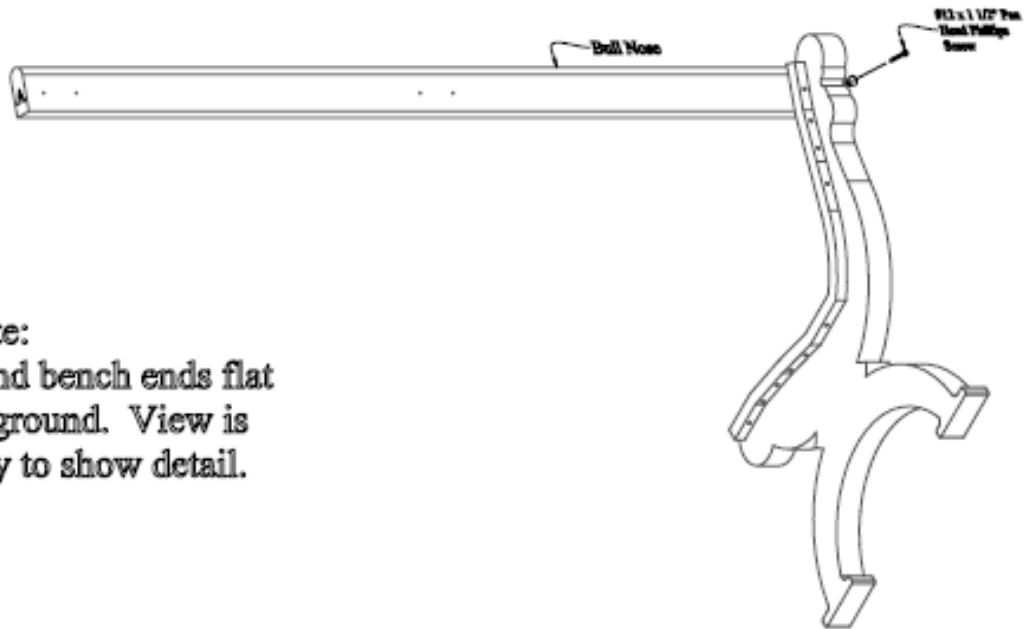
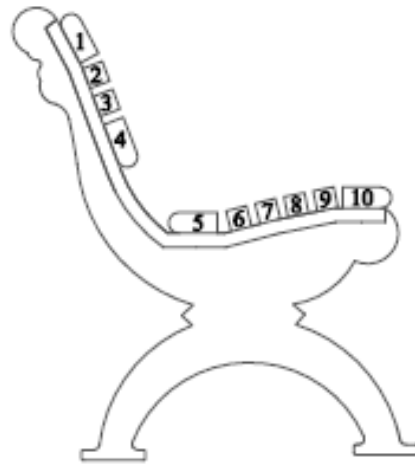

Note:

Stand bench ends flat on ground. View is only to show detail.

Step #1:

Stand (1) One bench end upright and place (1) One bull nose bench board (A) on position 1 being sure to align the pilot holes to the pre-drilled holes in the bench end. After the holes are properly aligned, fasten with (1) One #12 x 1 1/2" Pan Head Phillips Screw in the pre-drilled hole on the right side of the bench end.

Note: Do not tighten screw completely. This will be done in a later step.

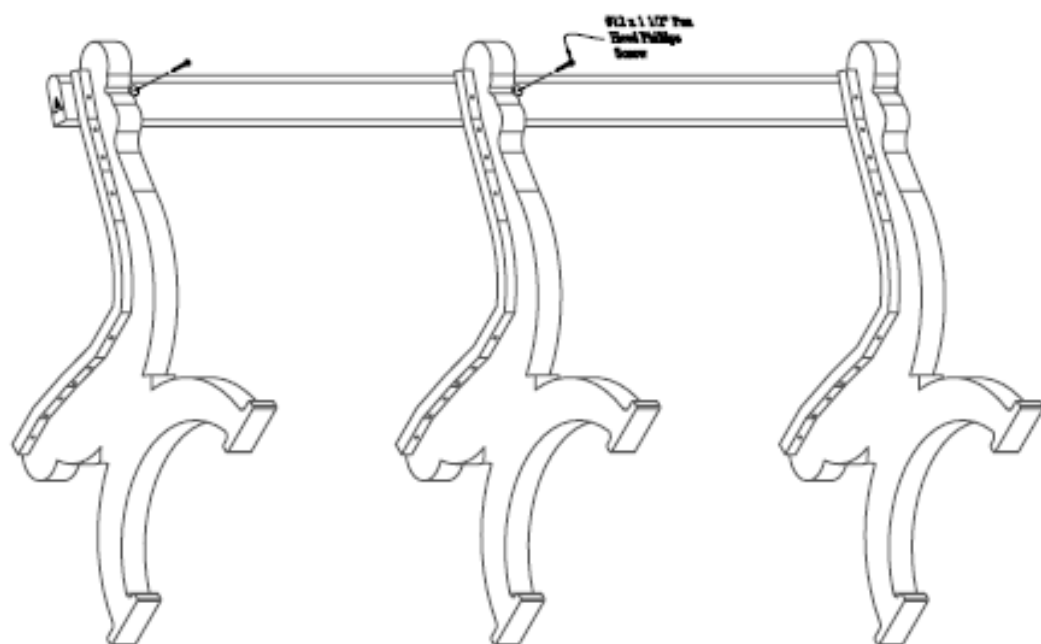

Step #2:

Stand the other (2) Two bench ends upright, one at a time, and place the bull nose bench board (A) already attached to the first bench end, on position 1 being sure to align the pilot holes with the pre-drilled holes in the bench end. After the holes are properly aligned, fasten with (1) One #12 x 1 1/2" Pan Head Phillips Screw in the pre-drilled hole on the right side of the bench end.

Note: Do not tighten screws completely. This will be done in a later step.

Step #3:

Align the pilot holes on the bull nose bench board (A) to the pre-drilled holes on the left side of the bench ends. After the holes are properly aligned, fasten with (1) One #12 x 1 1/2" F
Screw per bench end.

Note: Be sure to tighten screws completely after this step.

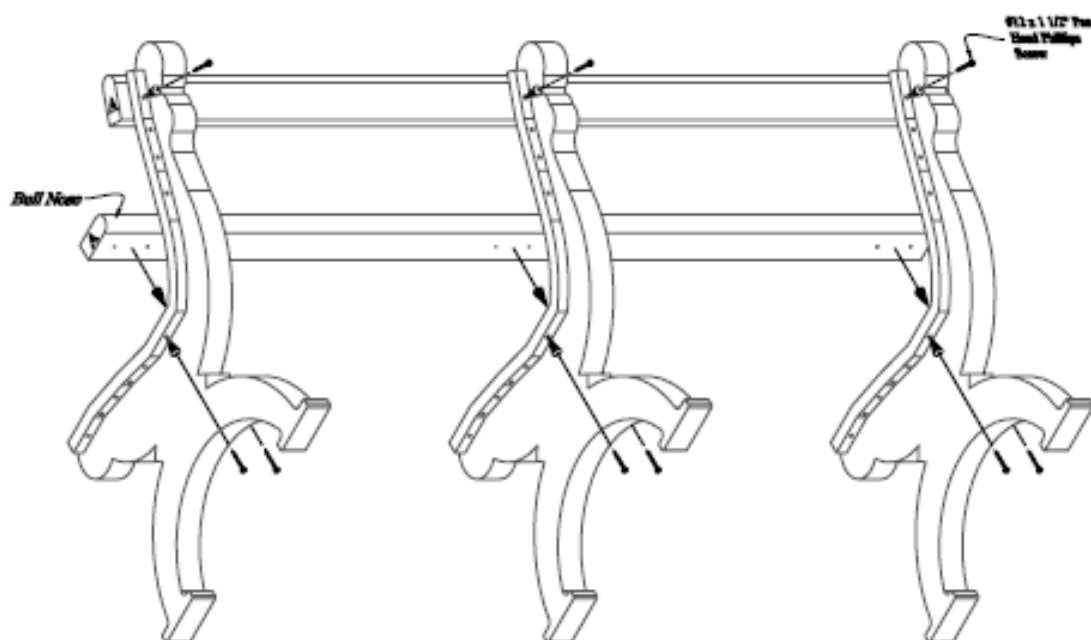

Step #4:

Place a bull nose bench board (A) on position 5. Repeat Steps 1 - 3 to attach. Use (1) One #12 x 1 1/2" Pan Head Phillips Screw per hole to fasten.

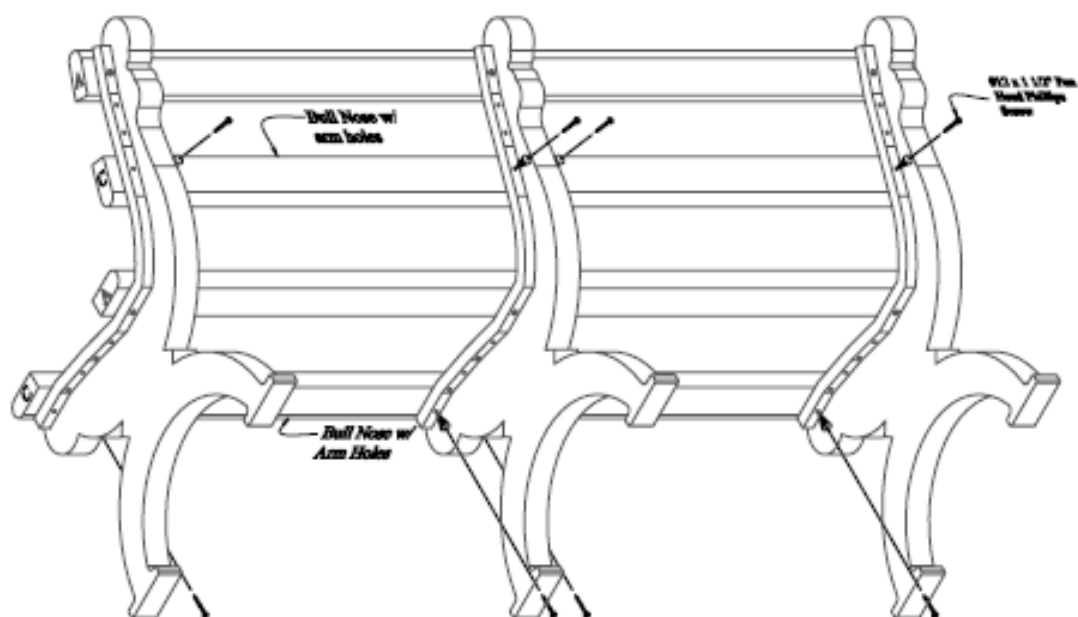

Step #5:

Repeat Steps 1 - 3 to attach bull nose bench boards w/ arm holes (C) on positions 4 & 10. Use (1) One #12 x 1 1/2" Pan Head Phillips Screw per hole to fasten with the exception of the arm holes.

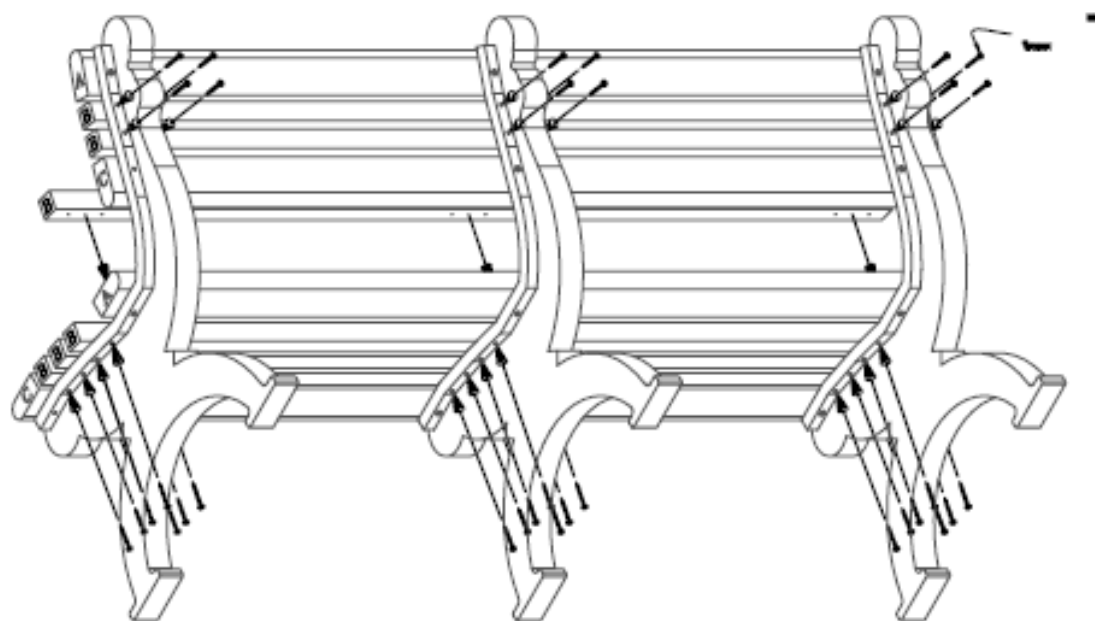

p #6:

Repeat Steps 1 - 3 to attach bench boards (B) on position

Use (1) One #12 x 1 1/2" Pan Head Phillips Screw per hole to fasten.

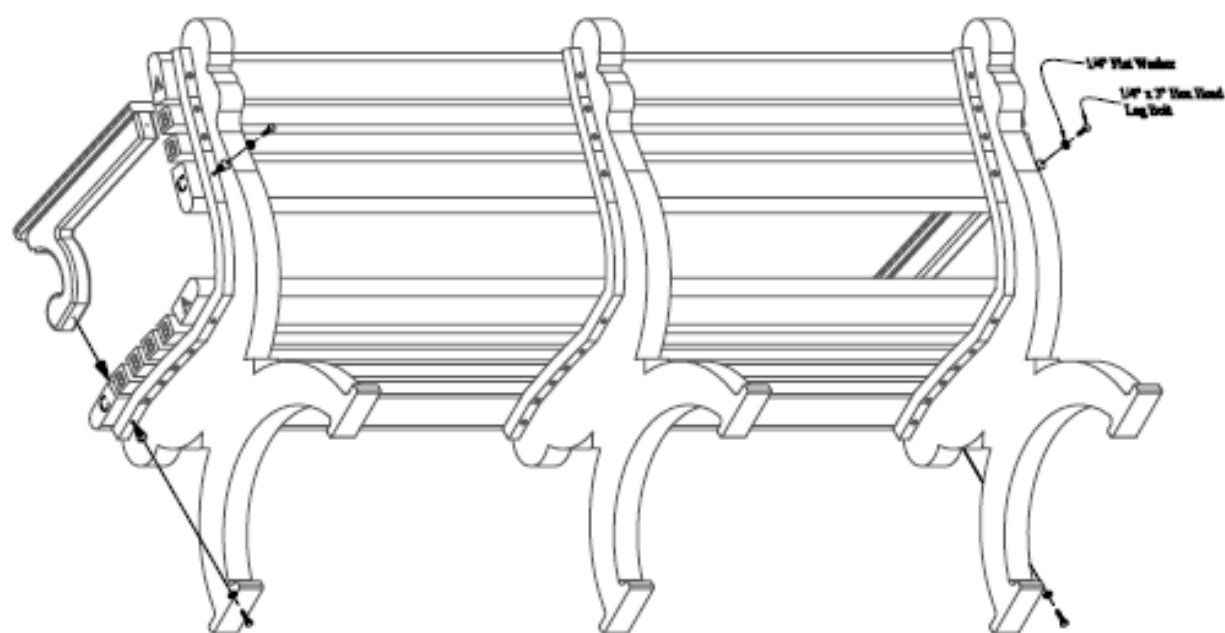

Step #7:

Align the pilot holes on the Arm to the pre-drilled holes on the bullnose bench boards w/ arm holes (C) and bench ends. After the holes are properly aligned, fasten with (1) One 1/4" Flat Washer and 1/4" x 3" Hex Head Lag Bolt per hole to fasten.