

8 Foot Cambridge Park Bench w/ Arms

For Fastener Pack
(FP-CB8BA-CU-02)

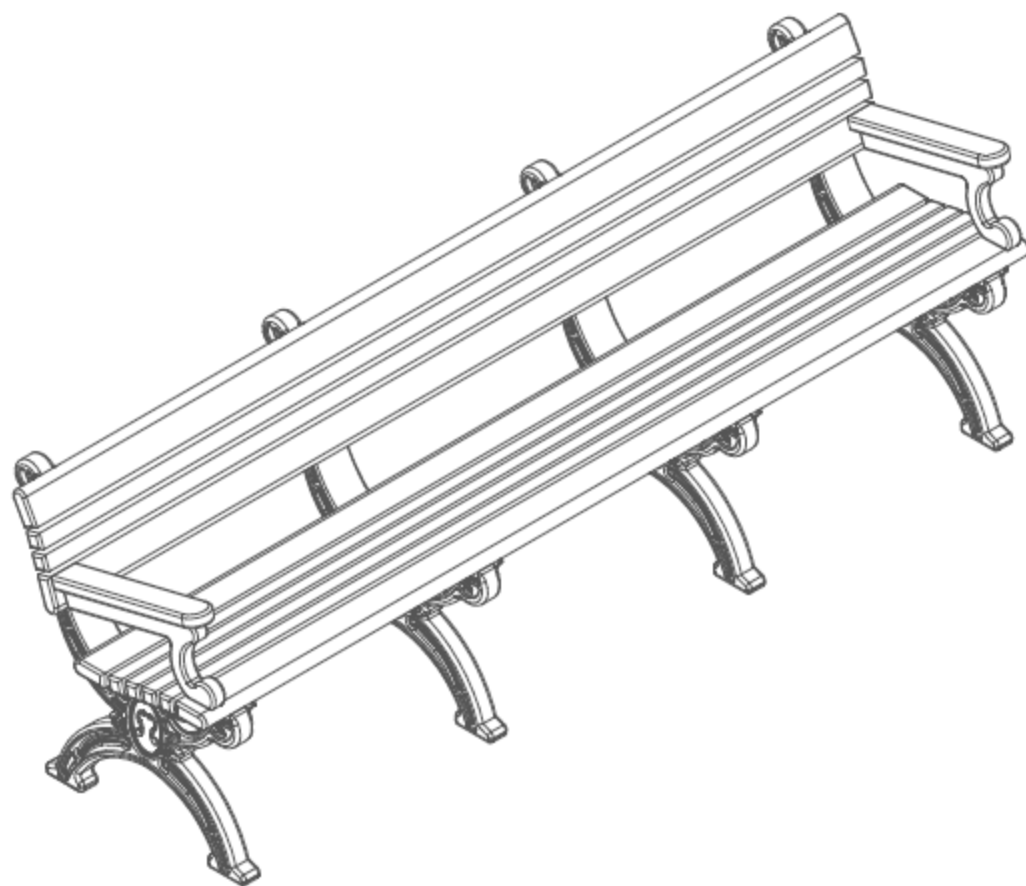

Congratulations !!

You have just purchased the finest recycled plastic
park bench available. Enjoy !!!

FS-CB8BA-CAP-02

Before assembly, please make sure all components are included.

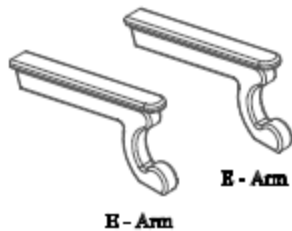

(2) - Two Arms
BSA-CBA-01



(1) - One Fastener Pack
FP-CB8BA-CU-02

FP - Fastener Pack

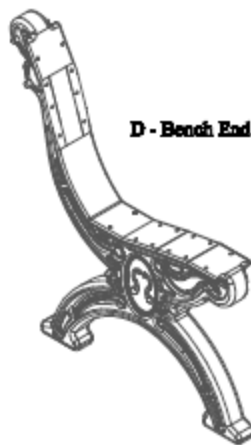

D - Bench End

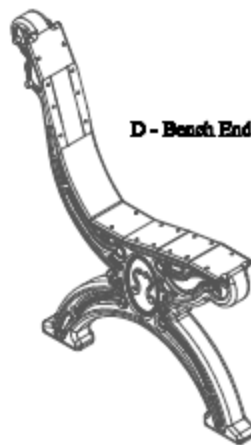

D - Bench End

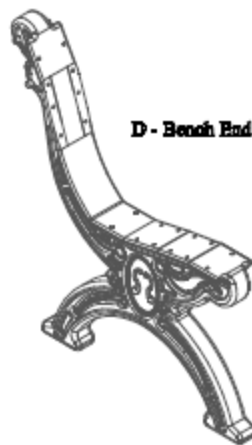

D - Bench End

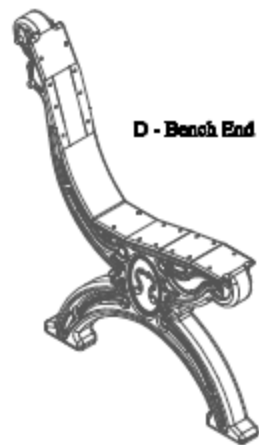

D - Bench End

(4) - Four Bench Ends
PS-CB8B-C-01

.	A - Bull Nose Bench Board	. . .
.	A - Bull Nose Bench Board	. . .

(2) - Two Bull Nose Bench Boards
BP-CB8B-A-02

.	B - Bench Board	. . .
.	B - Bench Board	. . .
.	B - Bench Board	. . .
.	B - Bench Board	. . .
.	B - Bench Board	. . .
.	B - Bench Board	. . .

(6) - Six Bench Boards
BP-CB8B-B-02

*	C - Bull Nose Bench Board w/ Arm Holes	. . . *
*	C - Bull Nose Bench Board w/ Arm Holes	. . . *

(2) - Two Bull Nose Bench Board w/ Arm Holes
BP-CB8BA-A-02

Before assembly, please make sure all fasteners are included.

80 - #12 x 1 1/2" Pan Head Phillips Screw



4 - 1/4" x 3" Hex Head Lag Bolt



4 - 1/4" Flat Washer



Also needed for this assembly will be the following materials:

1 - #3 Phillips Drive Bit

1 - 7/16" Socket Wrench

Fig #1:

In order to make the assembly of this Cambridge Bench easier while going through the assembly process the board positions are numbered and will be referenced in later steps.

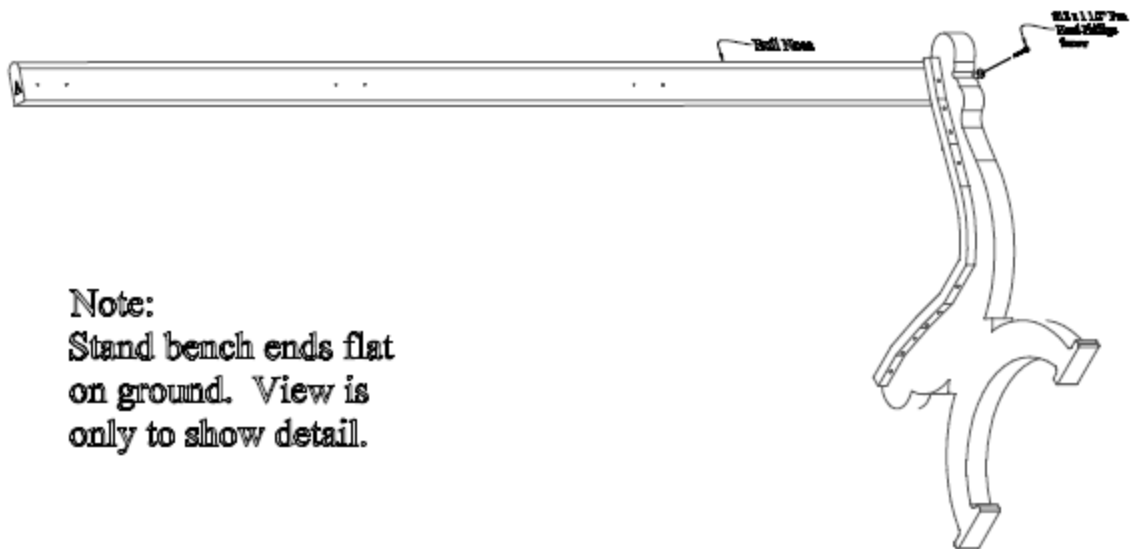
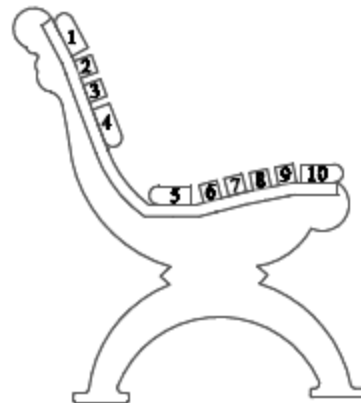

Note:

Stand bench ends flat on ground. View is only to show detail.

Step #1:

Stand (1) One bench end upright and place (1) One bull nose bench board (A) on position 1 being sure to align the pilot holes to the pre-drilled holes in the bench end. After the holes are properly aligned, fasten with (1) One #12 x 1 1/2" Pan Head Phillips Screw in the pre-drilled hole on the right side of the bench end.

Note: Do not tighten screw completely. This will be done in a later step.

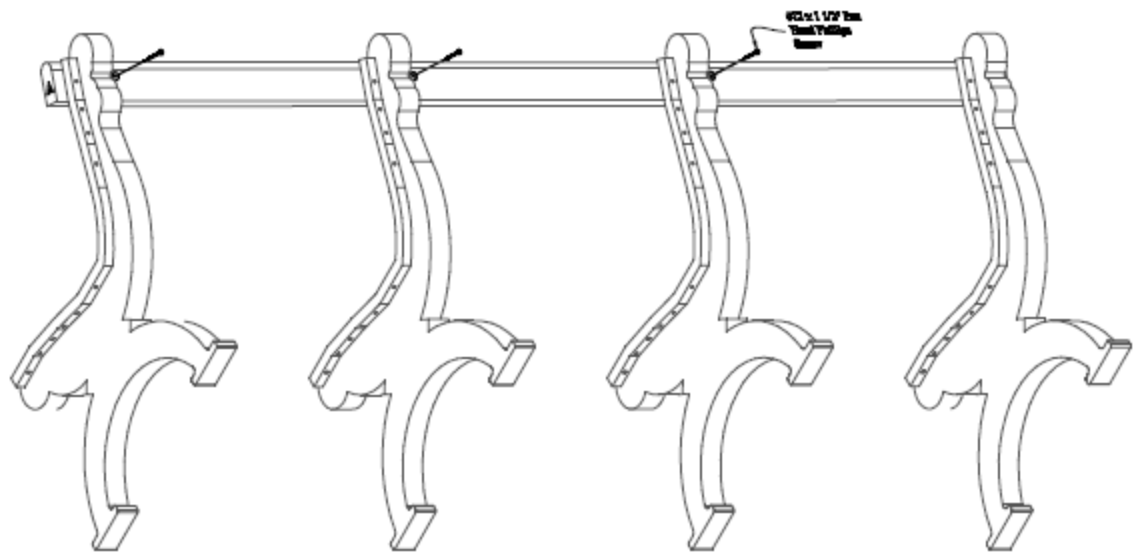

Step #2:

Stand the other (3) Three bench ends upright, one at a time, and place the bull nose bench board (A) already attached to the first bench end, on position 1 being sure to align the pilot holes with the pre-drilled holes in the bench end. After the holes are properly aligned, fasten with (1) One #12 x 1 1/2" Pan Head Phillips Screw in the pre-drilled hole on the right side of the bench end.

Note: Do not tighten screws completely. This will be done in a later step.

Step #3:

Align the pilot holes on the bull nose bench board (A) to the pre-drilled holes on the left side of the bench ends. After the holes are properly aligned, fasten with (1) One #12 x 1 1/2" Pan Head Phillips Screw per bench end.

Note: Be sure to tighten screws completely after this step.

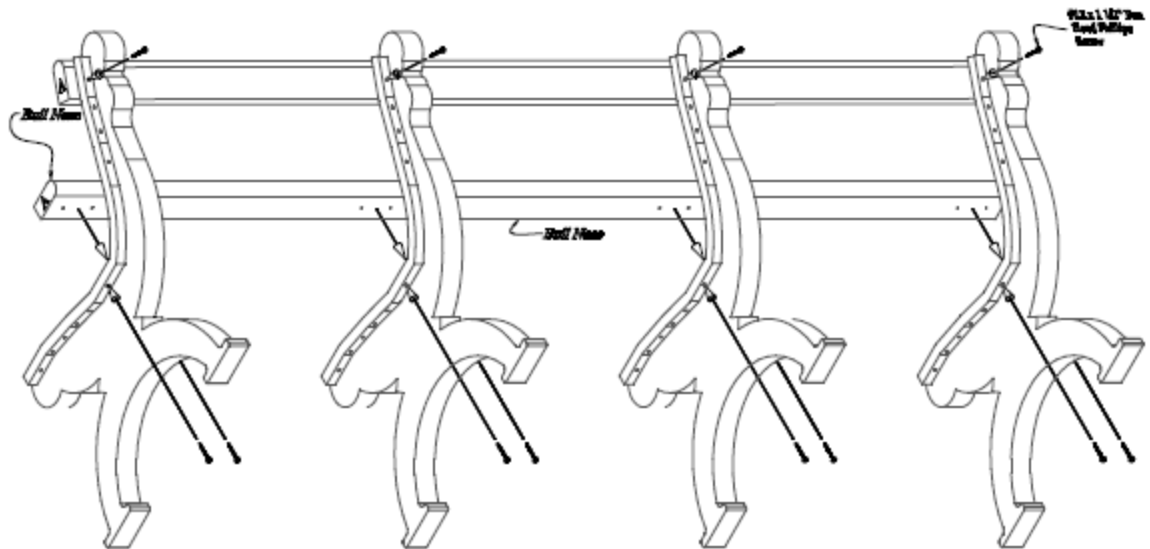

Step #4:

Place a second bull nose bench board (A) on position 5. Repeat Steps 1 - 3 to attach. Use (1) One #12 x 1 1/2" Pan Head Phillips Screw per hole to fasten.

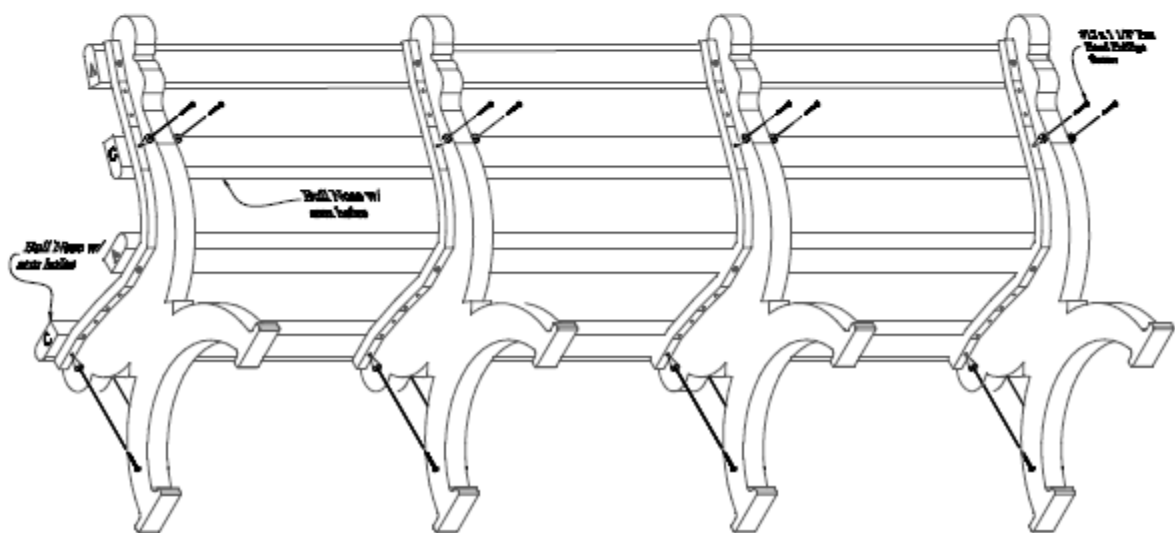

Step #5:

Repeat Steps 1 - 3 to attach bull nose bench boards w/ arm holes (C) on positions 4 & 10. Use (1) One #12 x 1 1/2" Pan Head Phillips Screw per hole to fasten.

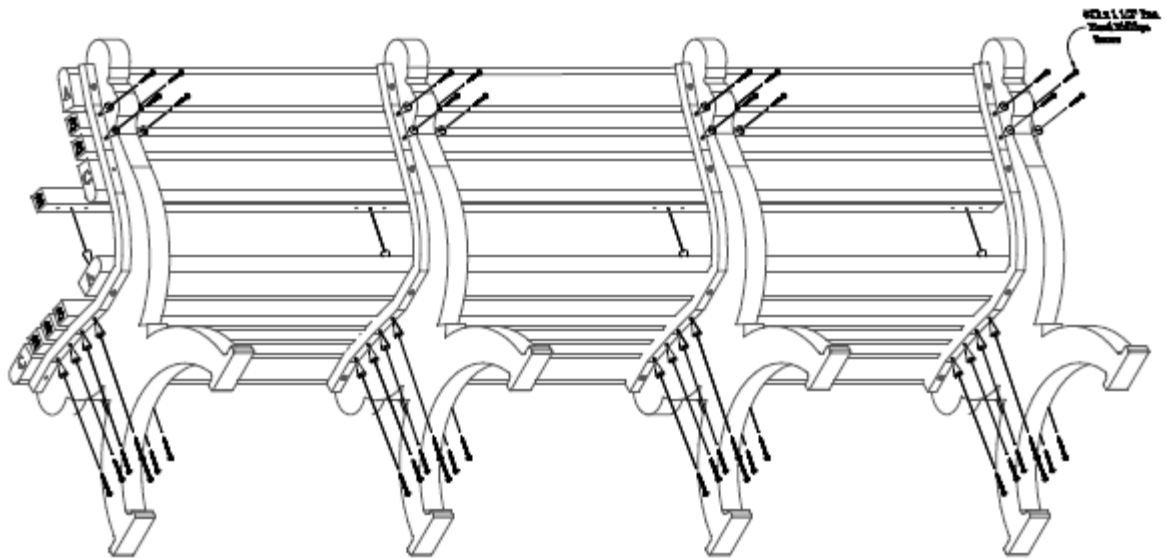

Step #6:

Repeat Steps 1 - 3 to attach bench boards (B) on positions 2, 3, 6, 7, 8 & 9.
Use (1) One #12 x 1 1/2" Pan Head Phillips Screw per hole to fasten.

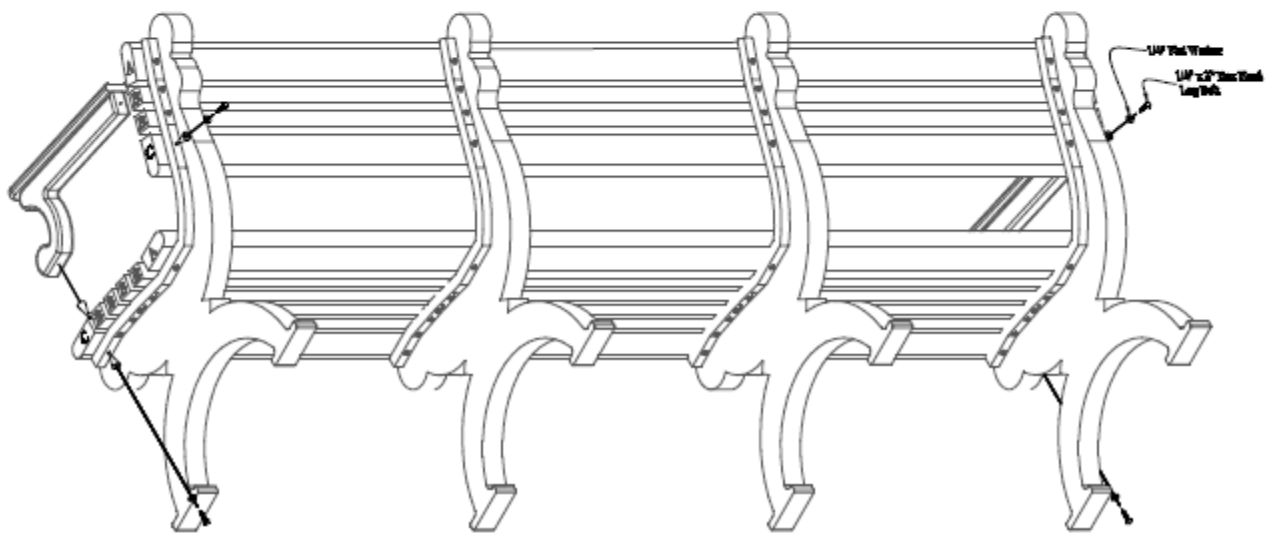

Step #7:

Align the pilot holes on the Arm to the pre-drilled holes on the bullnose bench boards w/ arm holes (C). After the holes are properly aligned, fasten with (1) One 1/4" Flat Washer and 1/4" x 3" Hex Head Lag Bolt per hole to fasten.