

Optional Bench Arm Assembly Instructions

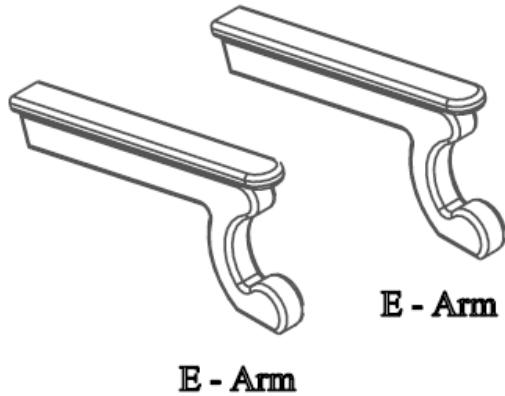

(2) - Two Arms
BSA-CBA-A-01

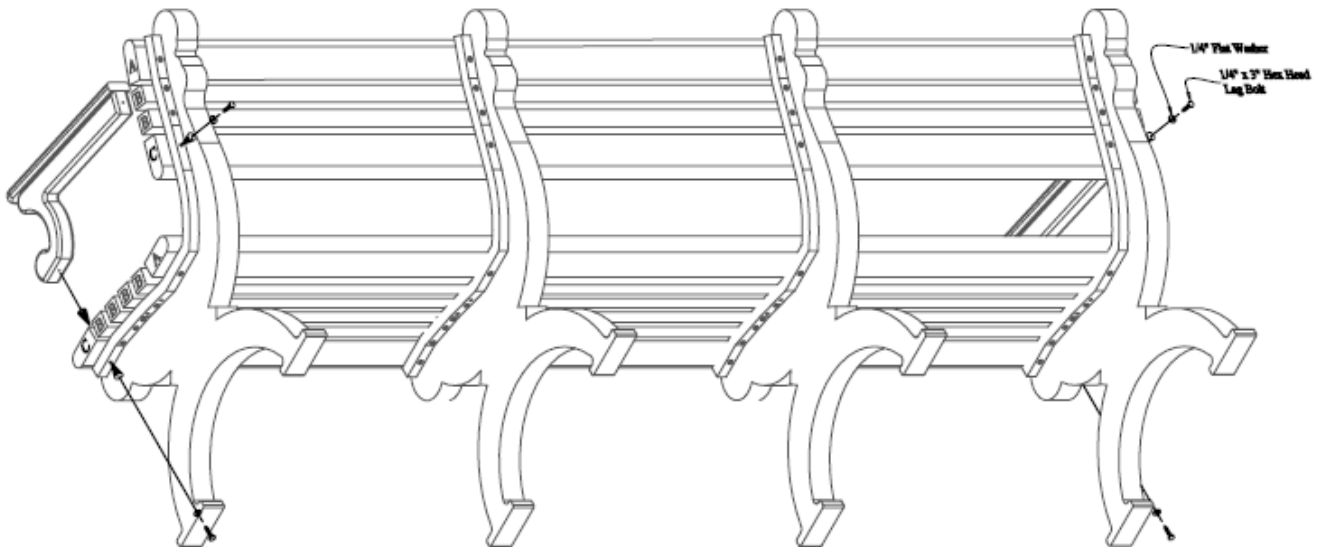

Align the pilot holes on the Arm to the pre-drilled holes on the bullnose bench boards w/ arm holes (C) and bench ends. After the holes are properly aligned, fasten with (1) One 1/4" Flat Washer and 1/4" x 3" Hex Head Lag Bolt per hole to fasten.