

Optional Bench Arm Assembly Instructions

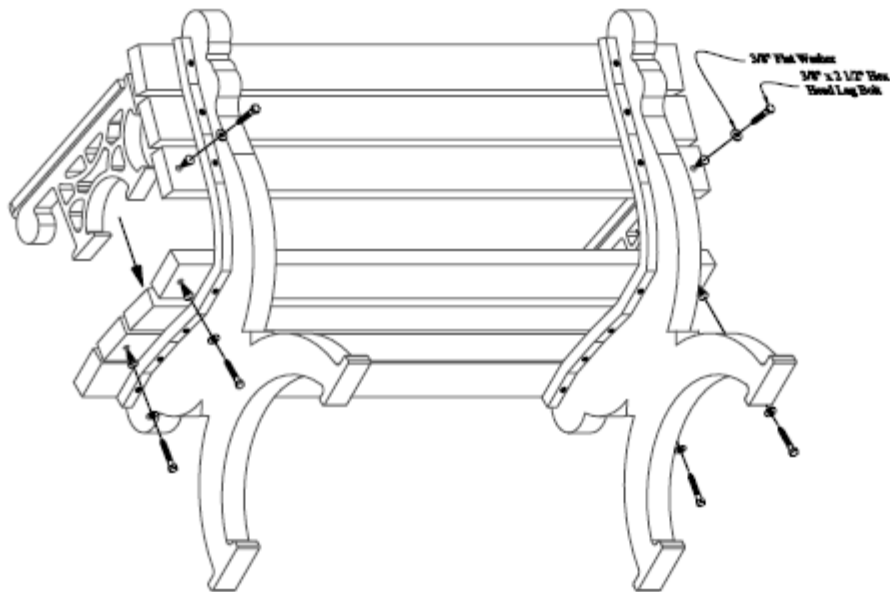

Step #7:

Place the arms on the bench boards fastened to positions 3, 4 & 6. Align the pre-drilled holes on the bench boards with the pilot holes in the arms. After the holes are properly aligned, fasten with (3) Three 3/8" Flat Washers along with (3) Three 3/8" x 2 1/2" Hex Head Lag Bolts.