

8 Foot Monarque Bench with Arms

For Fastener Pack
(FP-MB8BA-CU-01)

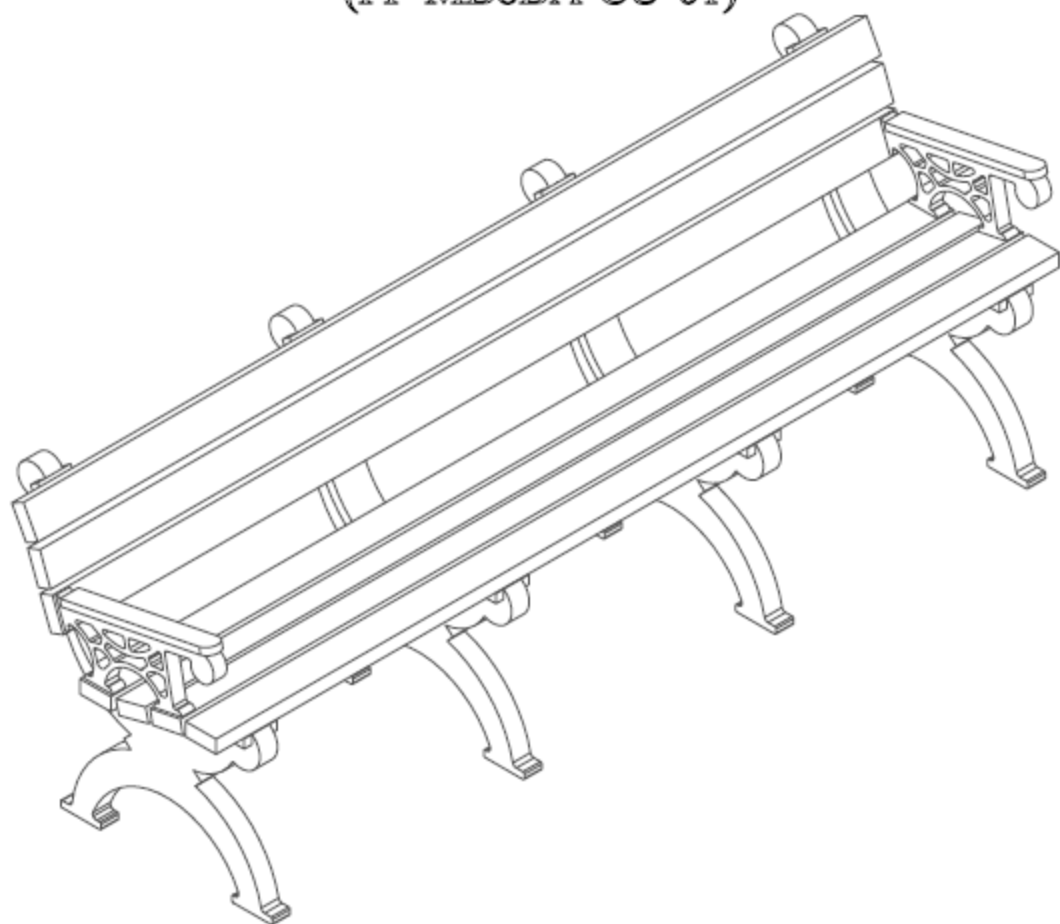

Congratulations !!

You have just purchased the finest recycled plastic
park bench available. Enjoy !!!

Before assembly, please make sure all components are included.

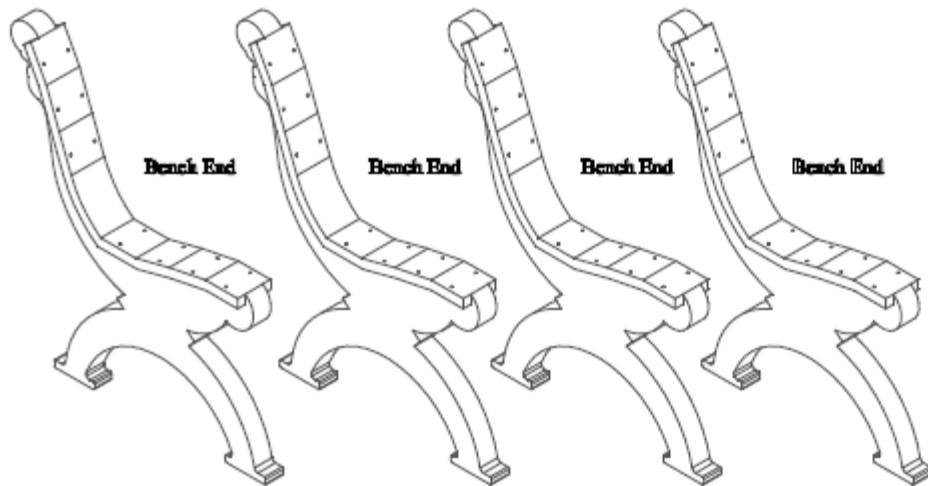

(4) - Four Bench Ends
PS-MB8E-M-01

• • • D - Bench Board w/ Arm Hole • •	• •	• • • •
• • • D - Bench Board w/ Arm Hole • •	• •	• • • •
• • • D - Bench Board w/ Arm Hole • •	• •	• • • •

(3) - Three Bench Boards w/ Arm Holes
BP-MB8BA-A-01

• •	• •	• •	• •
• •	• •	• •	• •
• •	• •	• •	• •
• •	• •	• •	• •

(4) - Four Bench Boards
BP-MB8B-A-01

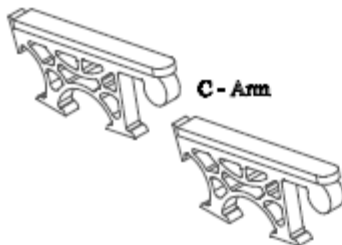

(2) - Two Arms
BBA-MBA-01

C - Arm

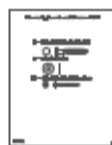

FP - Fastener Pack

(1) - One Fastener Pack
FP-MB8BA-CU-01

Before assembly, please make sure all fasteners are included.

6 - 3/8" x 2 1/2" Hex Head Lag Bolt

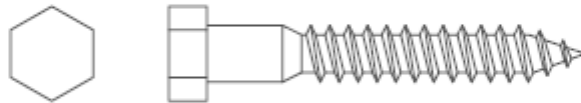

6 - 3/8" Flat Washer



56 - #12 x 2" Pan Head Phillips Screw



Also needed for this assembly will be the following materials:

1 - 9/16" Socket Wrench

1 - #3 Phillips Drive Bit

Fig #1:

In order to make the assembly of this Monarque Bench with Arms easier while going through the assembly process the board positions are numbered and will be referenced in later steps.

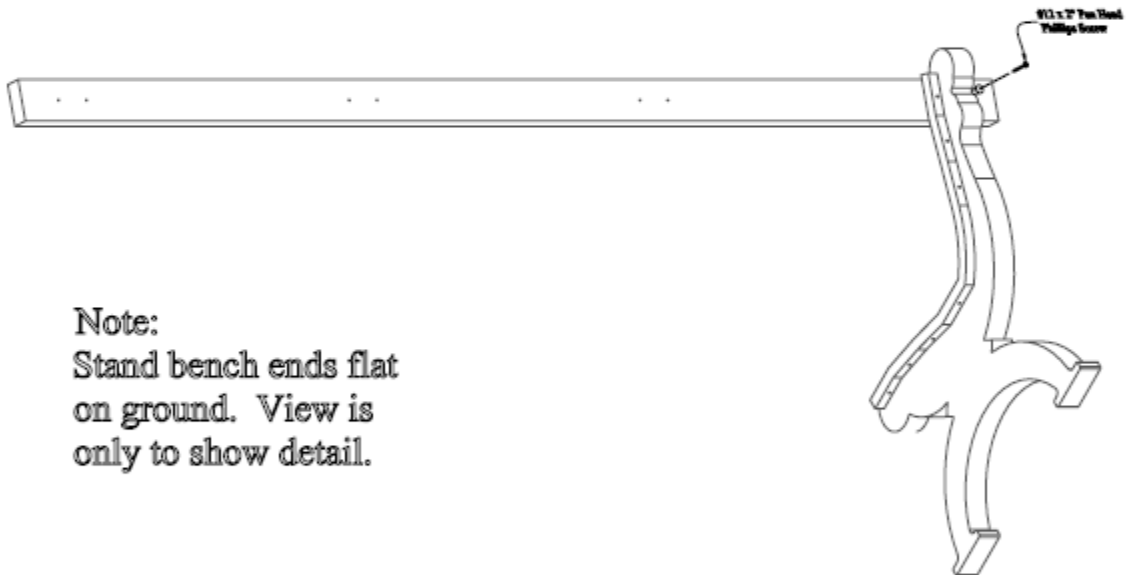
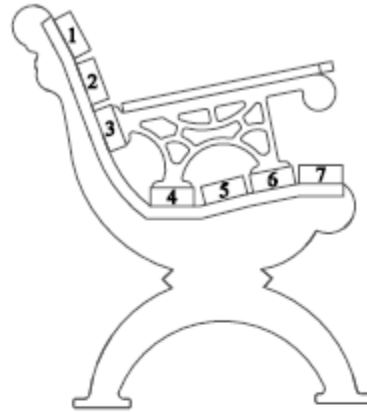

Note:

Stand bench ends flat on ground. View is only to show detail.

Step #1:

Stand (1) One bench end upright and place (1) One bench board (A) on position 1 being sure to align the pilot holes to the pre-drilled holes in the bench end. After the holes are properly aligned, fasten with (1) One #12 x 2" Pan Head Phillips Screw in the pre-drilled hole on the right side of the bench end.

Note: Do not tighten screw completely. This will be done in a later step.

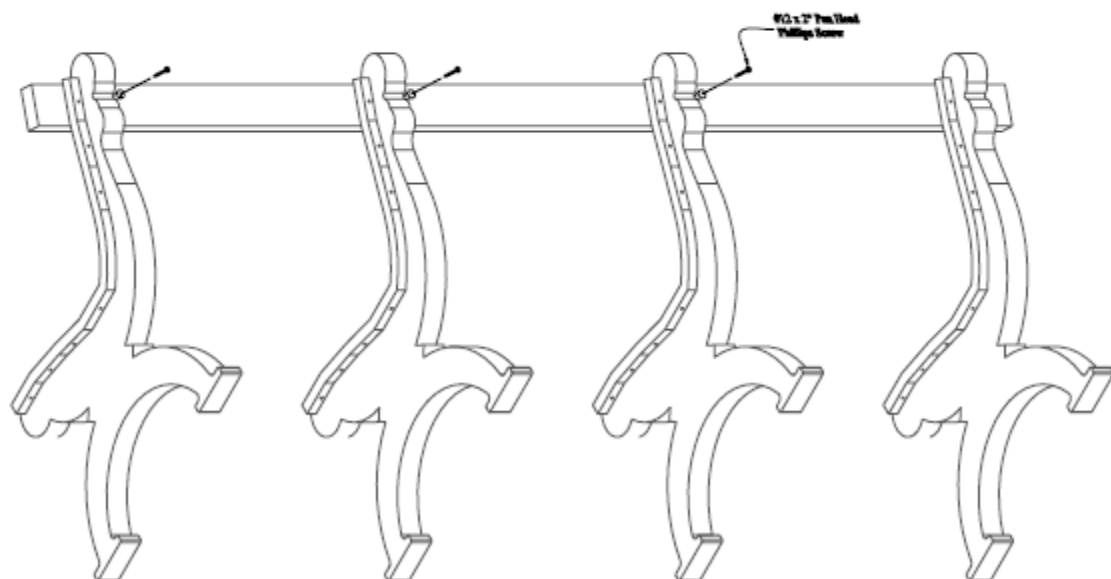

Step #2:

Stand the other (3) Three bench ends upright, one at a time, and place the bench board already attached to the first bench end, on position 1 being sure to align the pilot holes with the pre-drilled holes in the bench end. After the holes are properly aligned, fasten with (1) One #12 x 2" Pan Head Phillips Screw in the pre-drilled hole on the right side of the bench end.

Note: Do not tighten screws completely. This will be done in a later step.

Step #3:

Align the pilot holes on the bench board to the pre-drilled holes on the left side of the bench ends. After the holes are properly aligned, fasten with (1) One #12 x 2" Pan Head Phillips Screw per bench end.

Note: Be sure to tighten screws completely after this step.

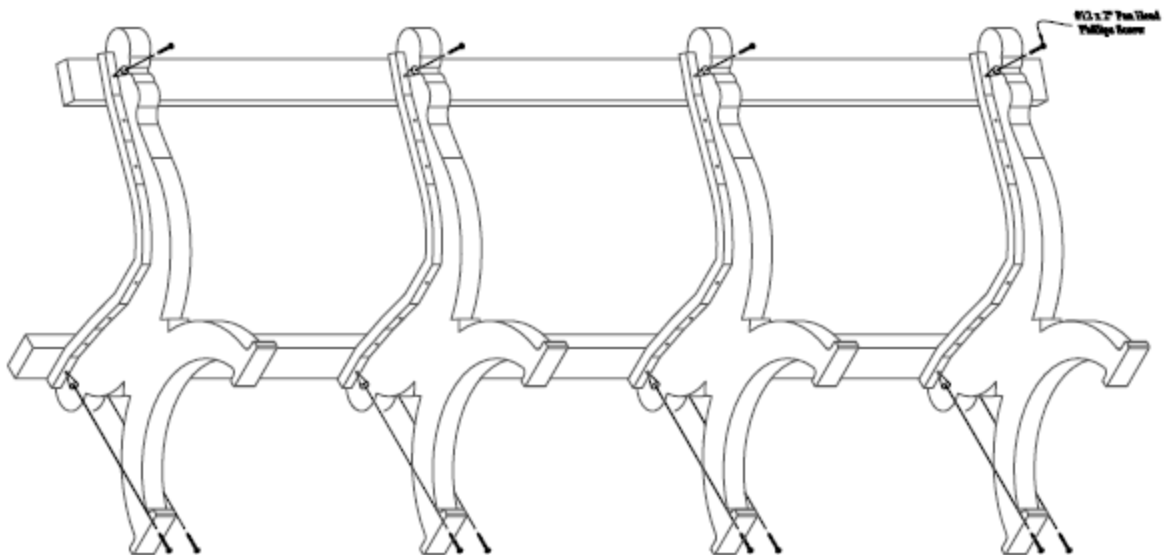

Step #4:

Place a second bench board (A) on position 7. Repeat Steps 1 - 3 to attach. Use (1) One #12 x 2" Pan Head Phillips Screw per hole to fasten.

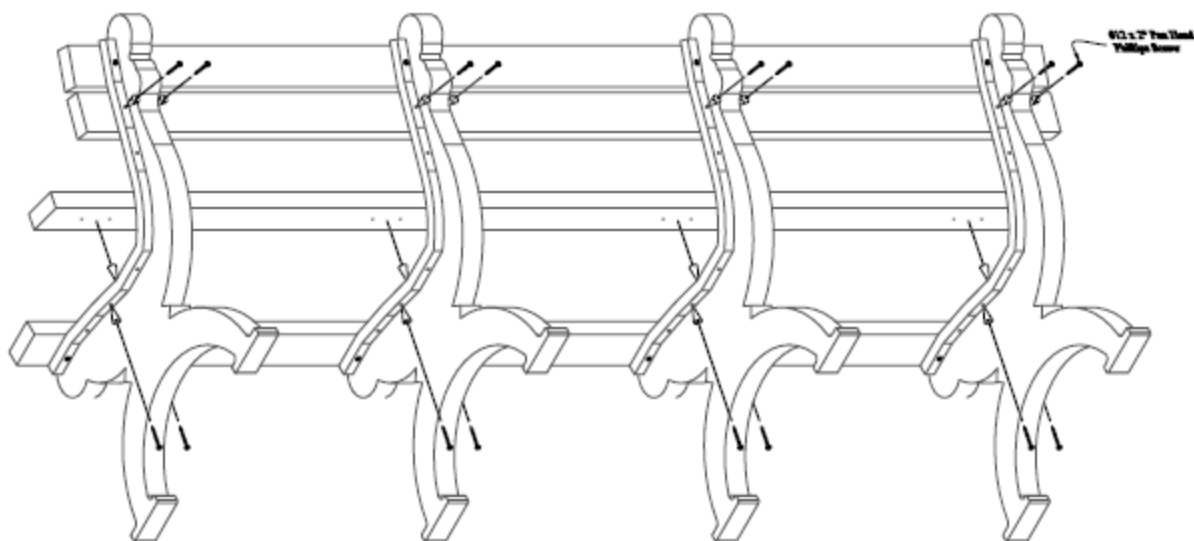

Step #5:

Repeat Steps 1 - 3 to attach bench boards (A) on positions 2 & 5. Use (1) One #12 x 2" Pan Head Phillips Screw per hole to fasten.

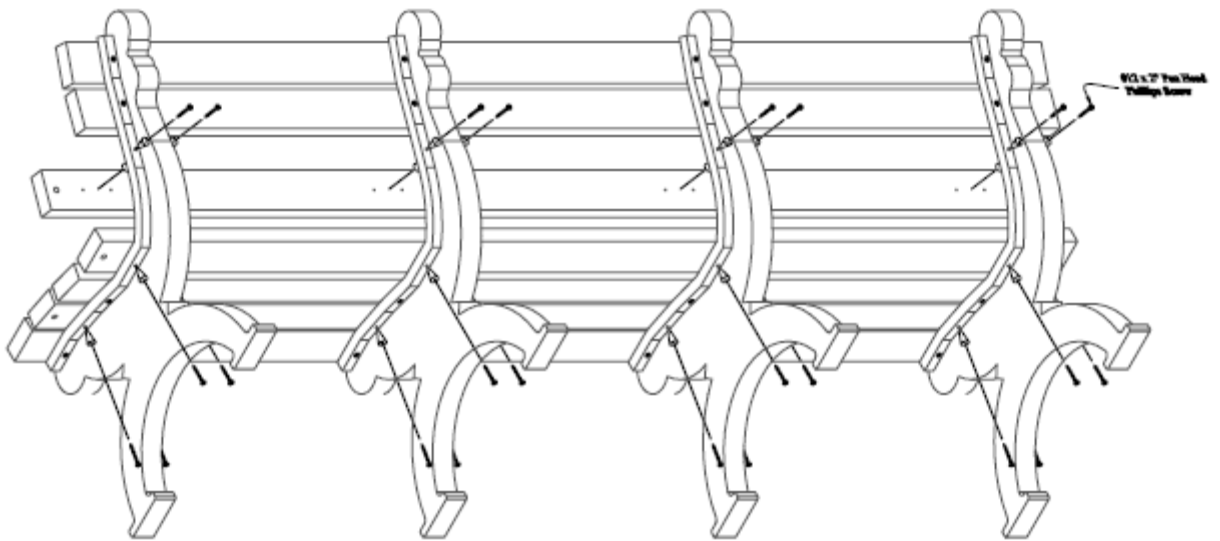

Step #6:

Repeat Steps 1 - 3 to attach bench boards with arm holes (B) on positions 3, 4 & 6. Use (1) One #12 x 2" Pan Head Phillips Screw per hole to fasten.

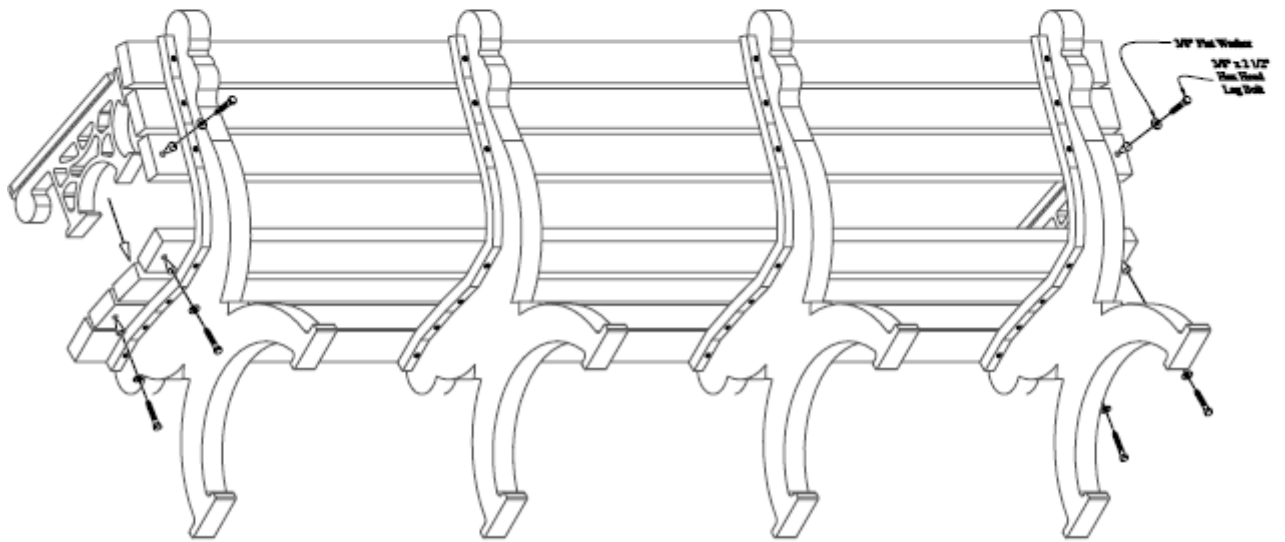

Step #7:

Place the arms on the bench boards fastened to positions 3, 4 & 6. Align the pre-drilled holes on the bench boards with the pilot holes in the arms. After the holes are properly aligned, fasten with (3) Three 3/8" Flat Washers along with (3) Three 3/8" x 2 1/2" Hex Head Lag Bolts.