

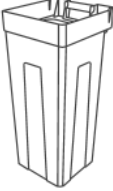

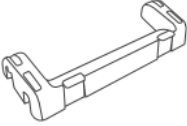

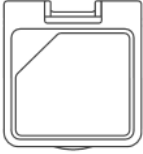

RISE CONTENTS AND ASSEMBLY

RISE™ Body	Pivot*	Lid*	Wall Extrusion* (2 End Caps included)	Wall Mount Bracket*	Signage (Optional)
					

*1 part per RISE™ body purchased

For BODY ASSEMBLY, please locate: 1x Pivot, 1x RISE™ Body (see chart above)

PIVOT INSTALLATION ON BODY:

1. Place body with the handle facing towards you. Located in the handle section are 2 tabs that the Pivot will insert into.
2. Holding the Pivot upright with tabs facing towards the liner, feed the Pivot's first holes into the tab of the body. The second hole on each side of the Pivot should remain exposed.
3. Continue this step for the other side of the Pivot.
4. The Pivot has now been fully installed.

For LID ASSEMBLY, please locate: 1x Lid, 1x RISE™ Body with Pivot Installed (see chart above)

LID INSTALLATION ON PIVOT:

1. Each lid contains 1 tab per side that are inserted into the Pivot attached to the body.
2. Feed one side of the tab into one of the remaining exposed holes of the Pivot.
3. Repeat this step until the other side of the lid has been inserted into the Pivot.
4. The lid has now been fully installed.
5. Apply label if purchased onto the triangular area of the lid.

For WALL EXTRUSION, please locate: 1x Wall Extrusion (see chart above), Recommended: 1x Level, 1x Stud Finder (if mounting directly into stud). Consult with your local hardware store for mounting hardware recommendations. It is recommended to mount the Wall Extrusion directly into a wall stud, drilling screws every 12" for maximized support.

WALL EXTRUSION INSTALLATION ON WALL:

1. After determining mounting location and hardware, drill directly into the Wall Extrusion through the concaved top & bottom track. It is recommended to use a level during installation to ensure that the Extrusion has been mounted level.

NOTE: If hardware is screwed through the middle portion of the Extrusion, the Wall Mount Bracket will not properly slide into the track.

2. Repeat step until all hardware has been installed into the Extrusion.

NOTE: Ensure precautions are taken while handling the Wall Extrusions, especially when removing the End Caps. It is recommended that Extrusions are mounted directly into wall studs with screws or drywall anchors inserted every 12" for optimum strength.

For WALL MOUNT BRACKET ASSEMBLY, please locate: Purchased amount of Wall Mount Brackets (see chart above)

WALL MOUNT BRACKET INSTALLATION ONTO WALL EXTRUSION

1. Carefully push the End Cap outwards from one end of the Wall Extrusion.
2. With the flat side of the Wall Mount Bracket facing the Wall Extrusion, slowly slide in the desired amount of Wall Mount Extrusions into the Wall Extrusion.
3. Once all Wall Mount Brackets have been inserted, reinstall the End Cap into the Wall Extrusion.
4. Bodies can now be placed onto the Wall Mount Bracket without further installation required.

NOTE: Ensure precautions are taken while handling the Wall Extrusions, especially when removing the End Caps.

OPTIONAL: For SIGNAGE ASSEMBLY, please locate: Signage amount purchased

SIGNAGE INSTALLATION ON WALL EXTRUSION

1. To install signage, pull the End Cap outwards until they disengage from the Extrusion bracket.
2. Slide desired signage onto the Extrusion channel as you want streams set-up (ex. Waste & Organics signage, you would slide the Waste signage in first, following the same step for Organic signage).
3. Continue Step 2 until all desired signage has been installed into the Extrusion.
4. Insert the End Cap into the Extrusion by sliding it in until resistance is felt.

IDEAL BAG SIZES

	RISE Body
Ideal Bag Size (inches)	24 x 36

CARE & MAINTENANCE

We recommend that a mild detergent be used (not an abrasive), such as a pH-neutral liquid (hand dishwashing or hand car washing soaps, for example) diluted in warm water. Rinse well with clean water. Any dirt adhering to the powder coating should be removed. In order to remove deposits such as salt or dust, use a soft brush (non-abrasive). If this is not sufficient to remove stubborn soiling, the following products have been tested for use:

NOTE: Always test soaps/cleaners on a hidden and/or small area beforehand

- Ajax Cream • Flash (in water)
- Liquid Gumption • Ajax Liquid (in water)
- Cutting Compound ('T. Cut')

If solvents are absolutely needed to remove marks, a soft cloth dampened with white spirit may be used.

GENERAL CARE

- Clean with a power washer or light scrub brush (outdoor/municipal bins)
- Clean with a mild detergent with damp sponge or cloth (indoor/office bins)
- For soil and stain remover, cleaners like Fantastik, Armor All or Acetone may be tried
- UV safe cleaners MUST be used on all outdoor bins

THINGS TO AVOID

- Cleaners with chloride or bleach
- Solvents
- Abrasive detergents
- Steel wool or Scouring pads