

6 Foot Silhouette Park Bench w/ Arms

For Fastener Pack
(FP-SB6BA-CU-02)

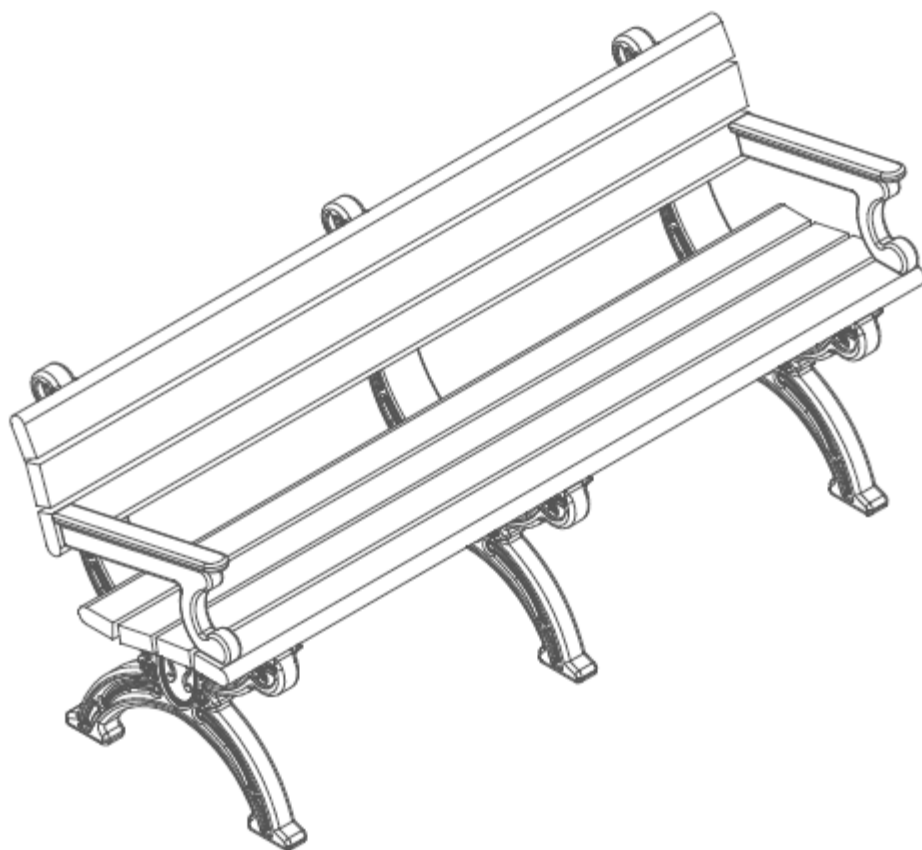

Congratulations ! !

You have just purchased the finest recycled plastic
park bench available. Enjoy ! ! !

FS-SB6BA-CAP-02

Before assembly, please make sure all components are included.

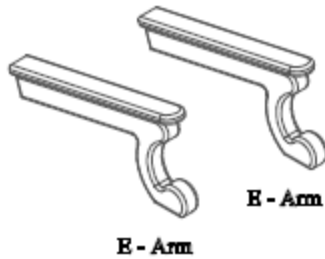

(2) - Two Arms
BSA-CBA-01



(1) - One Fastener Pack
FP-SB6BA-CU-02

FP - Fastener Pack

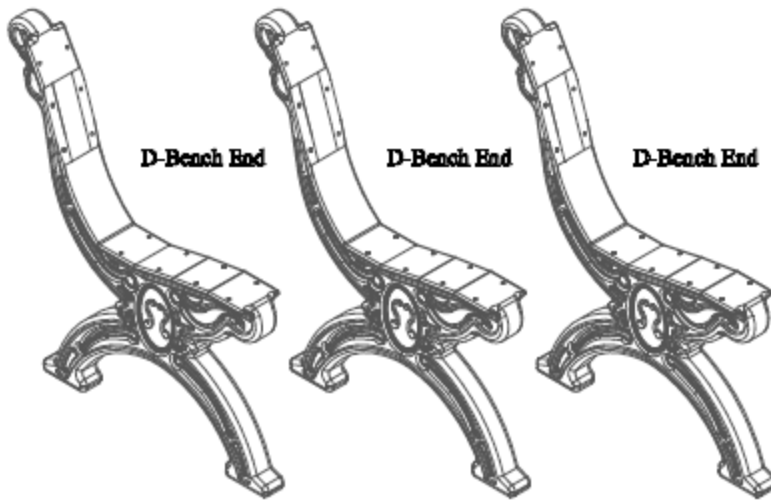

(3) - Three Bench Ends
PS-CBHE-S-01

• • C - Bull-nosed Bench Board w/ Arm holes	• •	• • •
• • C - Bull-nosed Bench Board w/ Arm holes	• •	• • •

(2) - Two Bull-nosed Bench Boards w/ Arm Holes
BP-CB6BA-A-02

• • A - Bench Board	• •	• •
• • A - Bench Board	• •	• •
• • A - Bench Board	• •	• •

(3) - Three Bench Boards
BP-SB6B-A-01

• • B - Bull-nosed Bench Board	• •	• •
• • B - Bull-nosed Bench Board	• •	• •

(2) - Two Bull-nosed Bench Boards
BP-CB6B-A-02

Before assembly, please make sure all fasteners are included.

42 - #12 x 1 1/2" Pan Head Phillips Screw



4 - 1/4" x 3" Hex Head Lag Bolt

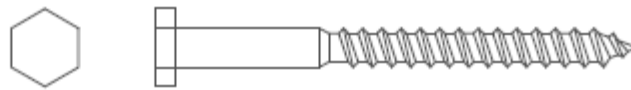

4 - 1/4" Flat Washer



Also needed for this assembly will be the following materials:

1 - #3 Phillips Drive Bit

1 - 7/16" Socket Wrench

Fig #1:

In order to make the assembly of this Silhouette Bench easier while going through the assembly process the board positions are numbered and will be referenced in later steps.

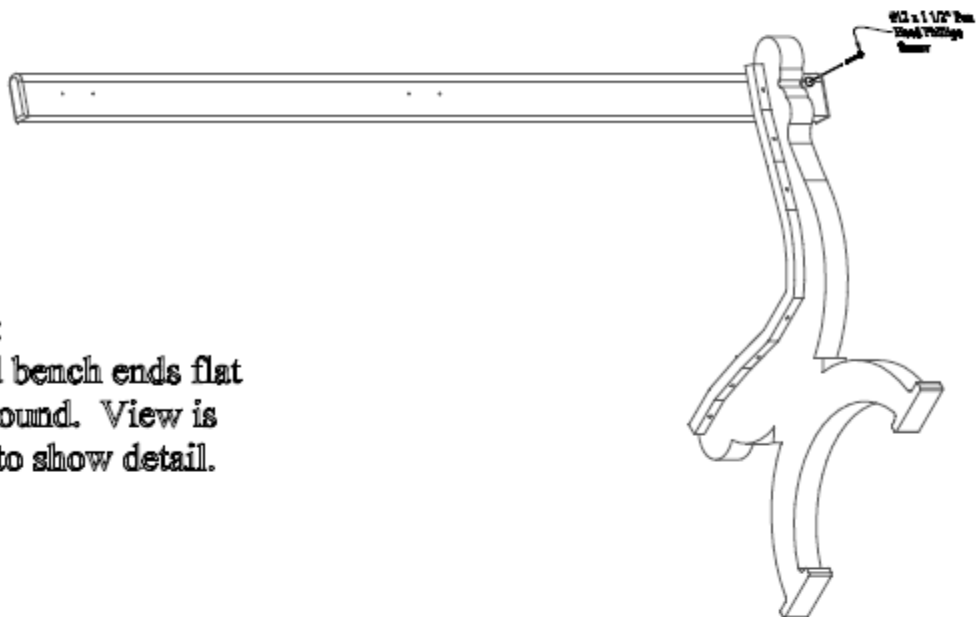
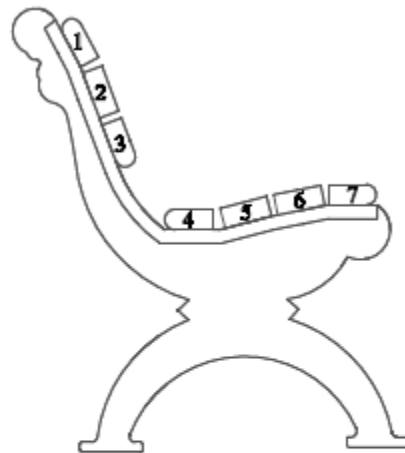

Note:

Stand bench ends flat on ground. View is only to show detail.

Step #1:

Stand (1) One bench end upright and place (1) One bull-nosed bench board (B) on position 1 being sure to align the pilot holes to the pre-drilled holes in the bench end. After the holes are properly aligned, fasten with (1) One #12 x 1 1/2" Pan Head Phillips Screw in the pre-drilled hole on the right side of the bench end.

Note: Do not tighten screw completely. This will be done in a later step.

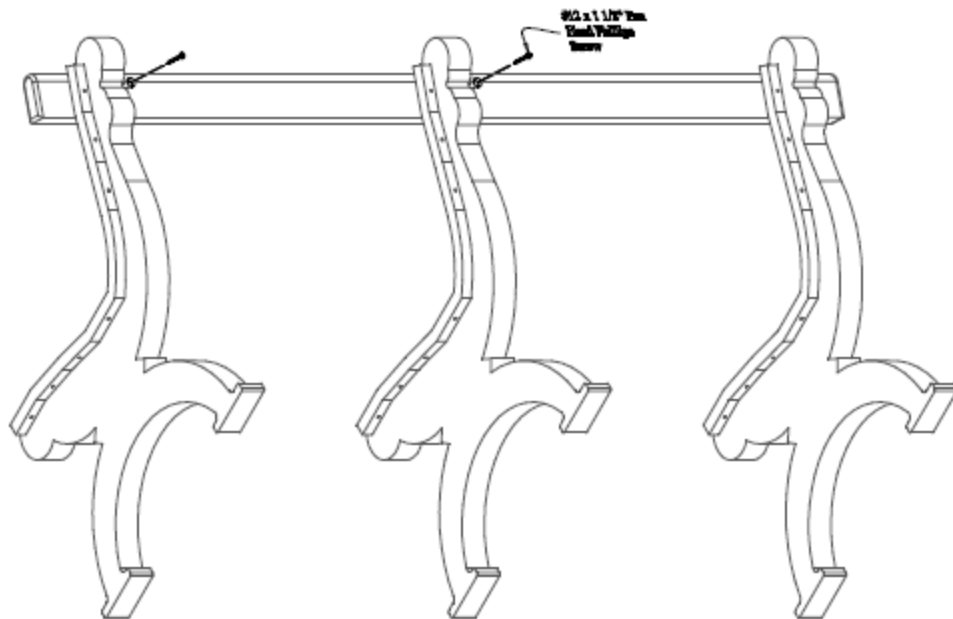

Step #2:

Stand the other (2) Two bench ends upright, one at a time, and place the bull-nosed bench board (B) already attached to the first bench end, on position 1 being sure to align the pilot holes with the pre-drilled holes in the bench end. After the holes are properly aligned, fasten with (1) One #12 x 1 1/2" Pan Head Phillips Screw in the pre-drilled hole on the right side of the bench end.

Note: Do not tighten screws completely. This will be done in a later step.

Step #3:

Align the pilot holes on the bull-nosed bench board (B) to the pre-drilled holes on the left side of the bench ends. After the holes are properly aligned, fasten with (1) One #12 x 1 1/2" Pan Head Phillips Screw per bench end.

Note: Be sure to tighten screws completely after this step.

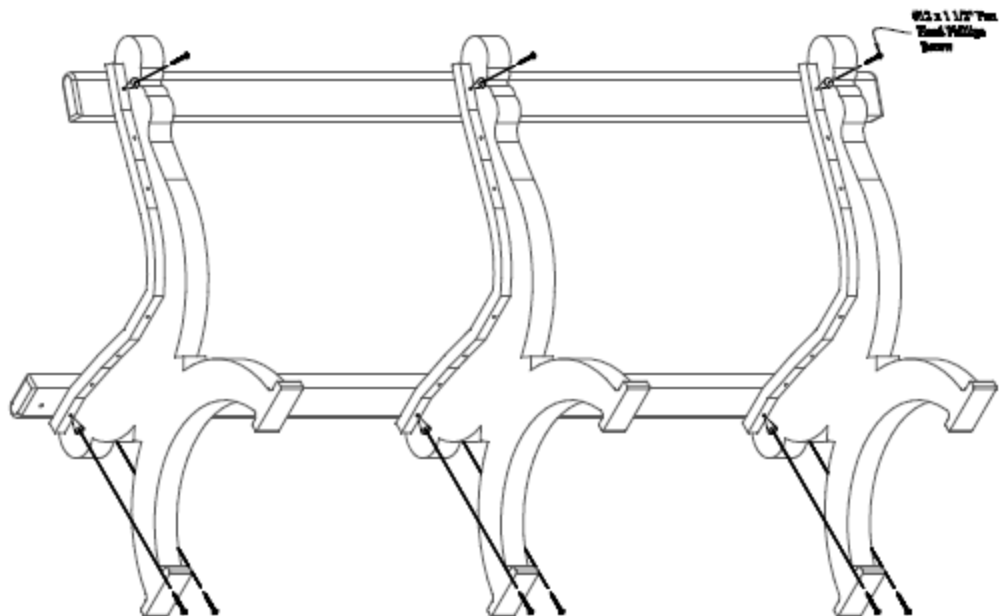

Step #4:

Place a bull-nosed bench board w/ arm holes (C) on position 7. Repeat Steps 1 - 3 to attach. Use (1) One #12 x 1 1/2" Pan Head Phillips Screw per hole to fasten.

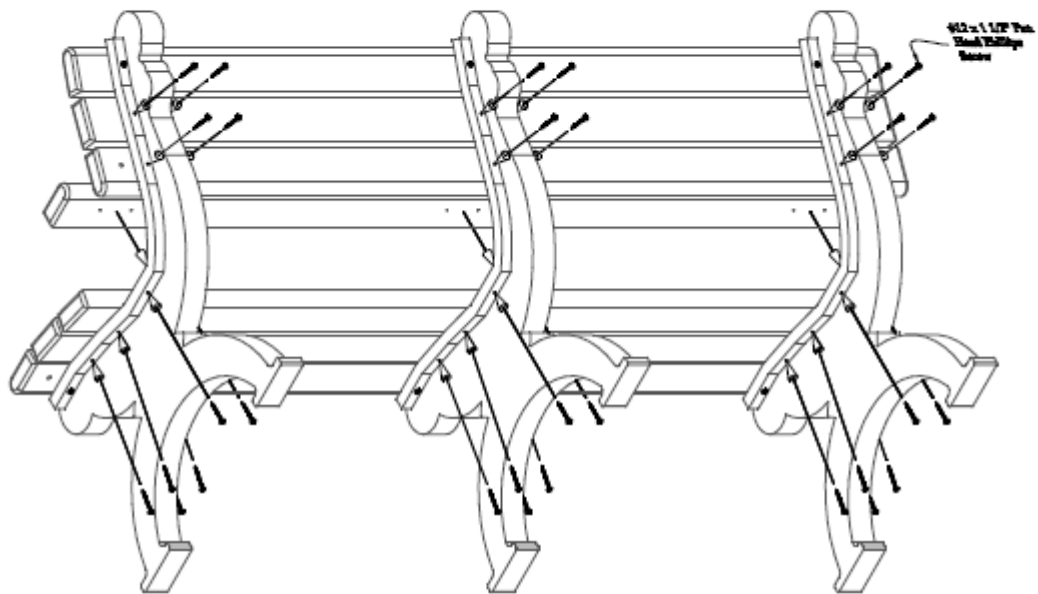

Step #5:

Repeat Steps 1 - 3 to attach bench boards (A) on positions 2, 5 & 6 and bull-nosed bench boards w/ arm holes (C) on positions 3 and a bull-nosed bench board (B) on position 4. Use (1) One #12 x 1 1/2" Pan Head Phillips Screw per hole to fasten.

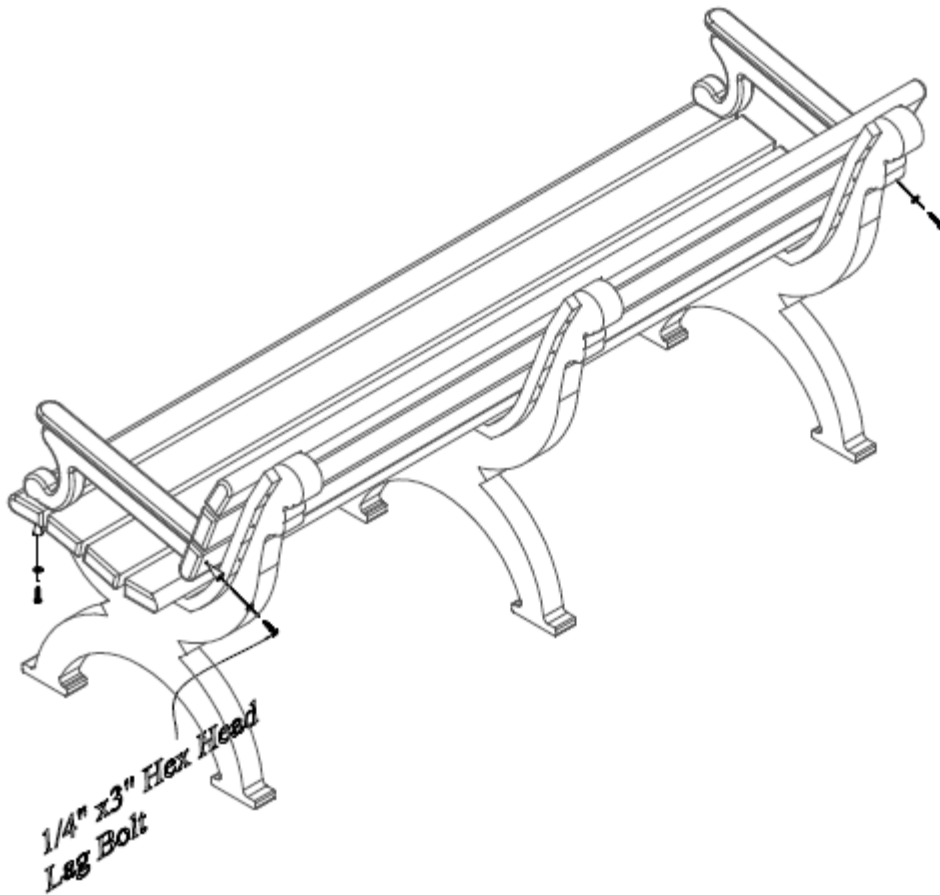

Step #6:

Align the pilot holes on the Arm to the pre-drilled holes on the bullnose bench boards w/arm holes (C). After the holes are properly aligned, fasten with (1) One 1/4" Flat washer and 1/4" x3" Hex Head Lag Bolt per hole to fasten.