

# Optional Bench Arm Assembly Instructions

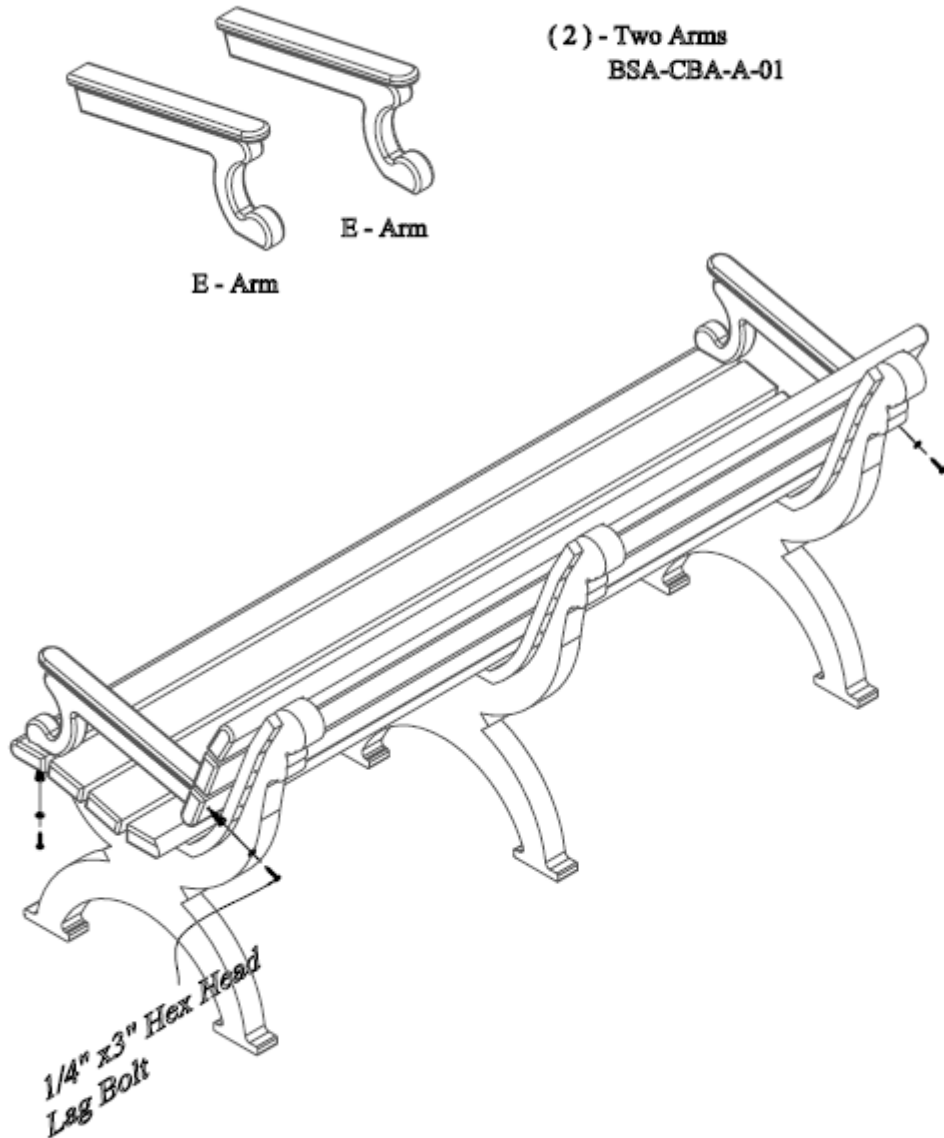

Align the pilot holes on the Arm to the pre-drilled holes on the bullnose bench boards w/arm holes (C). After the holes are properly aligned, fasten with (1) One 1/4" Flat washer and 1/4" x3" Hex Head Lag Bolt per hole to fasten.