

8 Foot Traditional Park Bench w/ Veterans Engraving

For Fastener Pack
(FP-VET8B-CU-00)

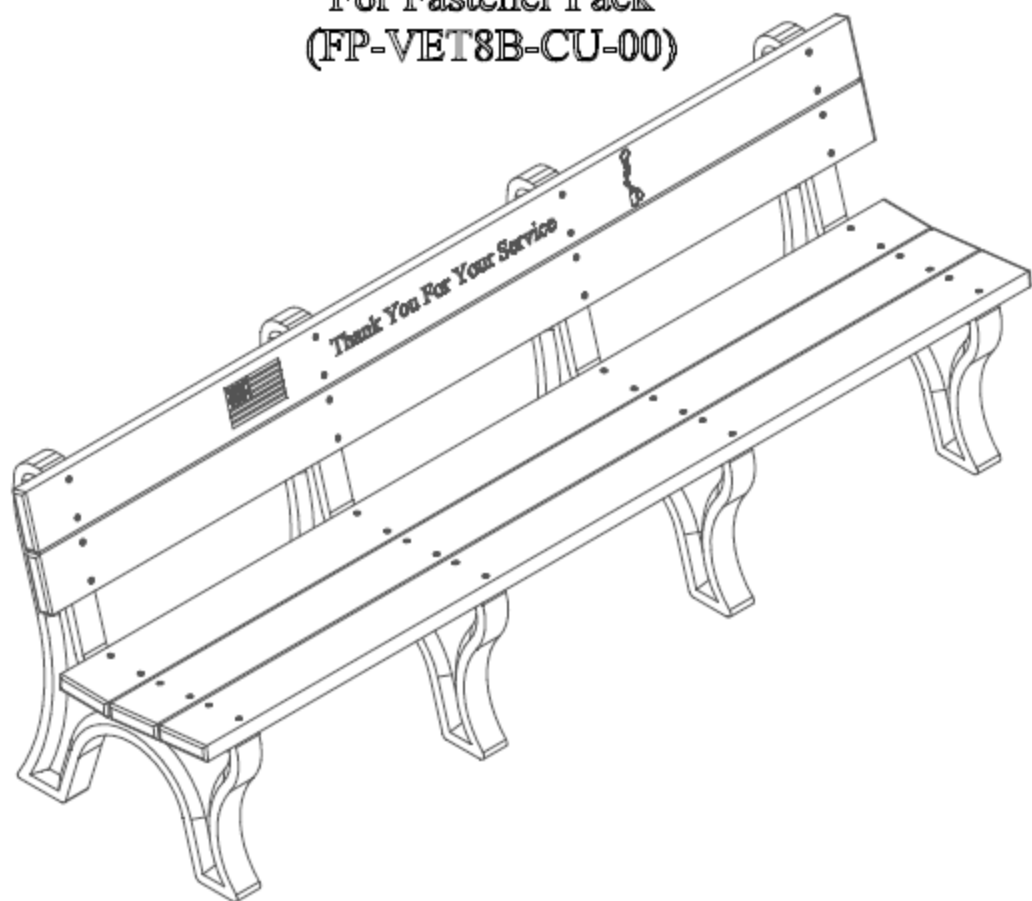

Congratulations !!
You have just purchased the finest recycled plastic
park bench available. Enjoy !!!

FS-VET8B-CAP-00

Before assembly, please make sure all components are included.



(1) - One Fastener Pack
FP-VET8B-CU-00

FP - Fastener Pack

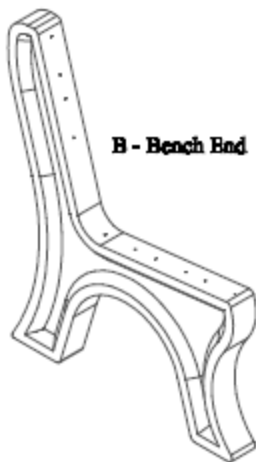

B - Bench End

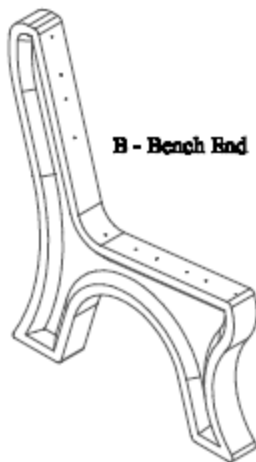

B - Bench End

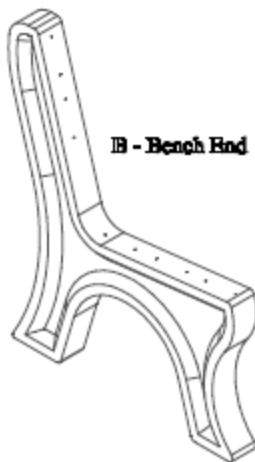

B - Bench End

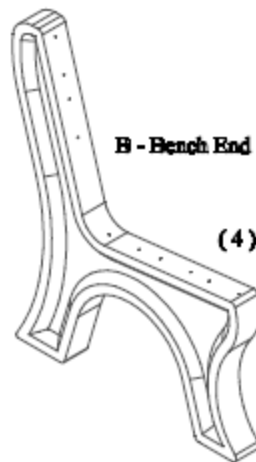

B - Bench End

(4) - Four Bench Ends
PS-SBBE-T-02



(1) - One Veterans Bench Board
BP-VET8B-A-00

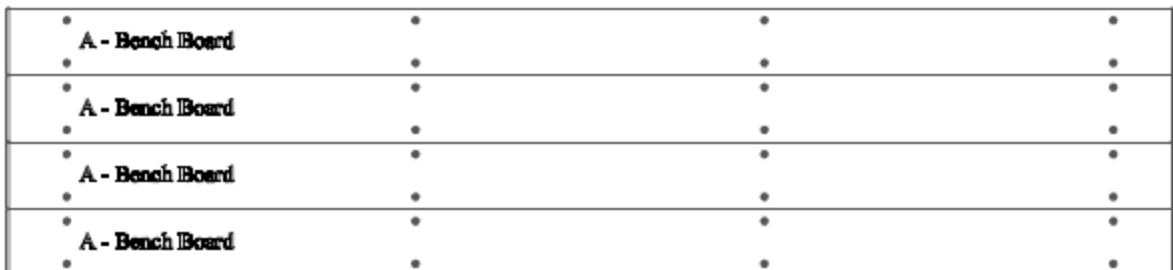

(4) - Four Bench Boards
BP-TB8B-A-02

Before assembly, please make sure all fasteners are included.

40 - #12 x 3" Flat Head Phillips Screw



Also needed for this assembly will be the following materials:

1 - #3 Phillips Drive Bit

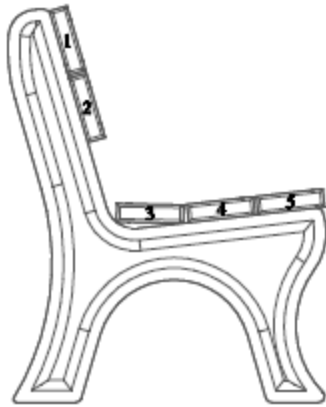
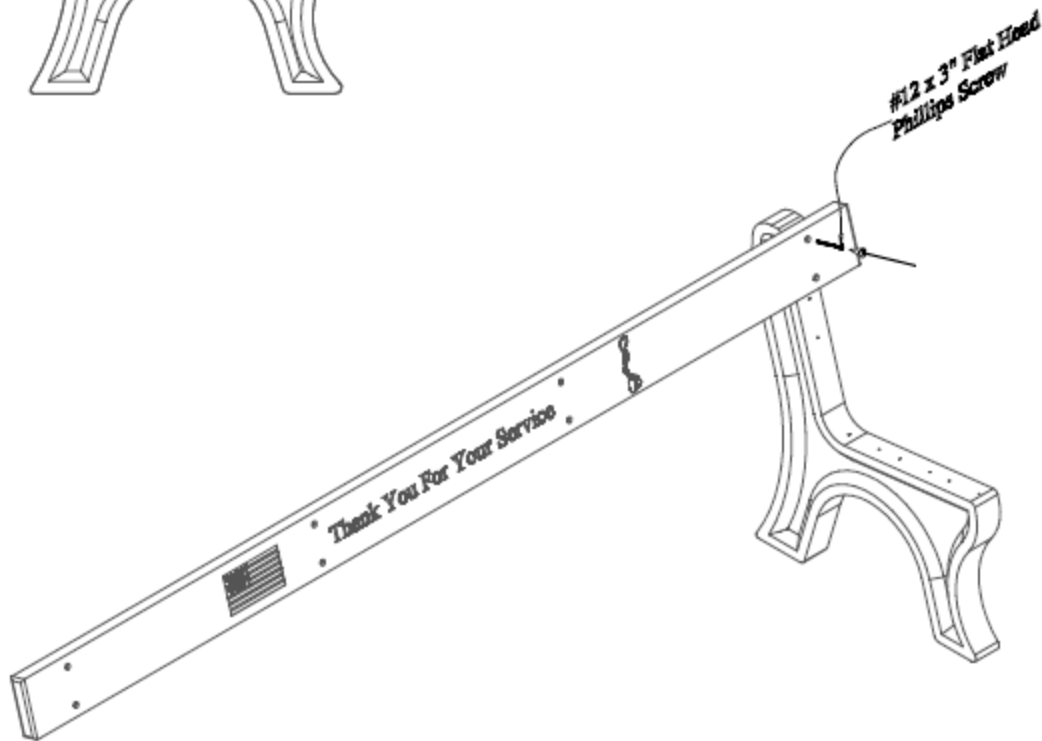

Fig #1:

In order to make the assembly of this Traditional Bench easier while going through the assembly process the board positions are numbered and will be referenced in later steps.



Step #1:

Stand (1) One bench end upright and place (1) One bench board on position 1 being sure to align the pre-drilled holes to the pilot holes in the bench end. After the holes are properly aligned, fasten with (1) One #12 x 3" Flat Head Phillips Screw in the top pre-drilled hole.

Note: Do not tighten screw completely. This will be done in a later step.

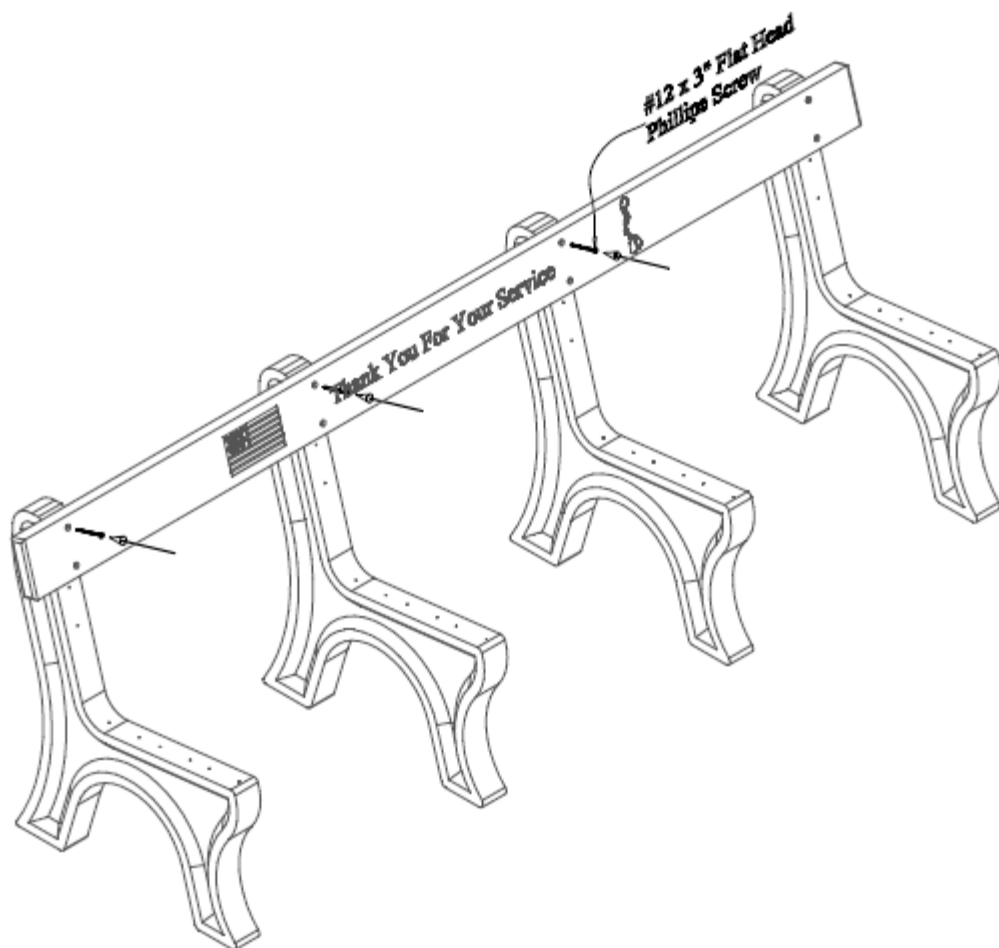

Step #2:

Stand the other (3) Three bench ends upright, one at a time, and place the bench board already attached to the first bench end, on position 1 being sure to align the pre-drilled holes to the pilot holes in the bench end. After the holes are properly aligned, fasten with (1) One #12 x 3" Flat Head Phillips Screw in the top pre-drilled hole.

Note: Do not tighten screws completely. This will be done in a later step.

Step #3:

Align bottom pre-drilled holes to the pilot holes in the bench end. After the holes are properly aligned, fasten with (1) One #12 x 3" Flat Head Phillips Screw per hole.

Note: Be sure to tighten screws completely after this step.

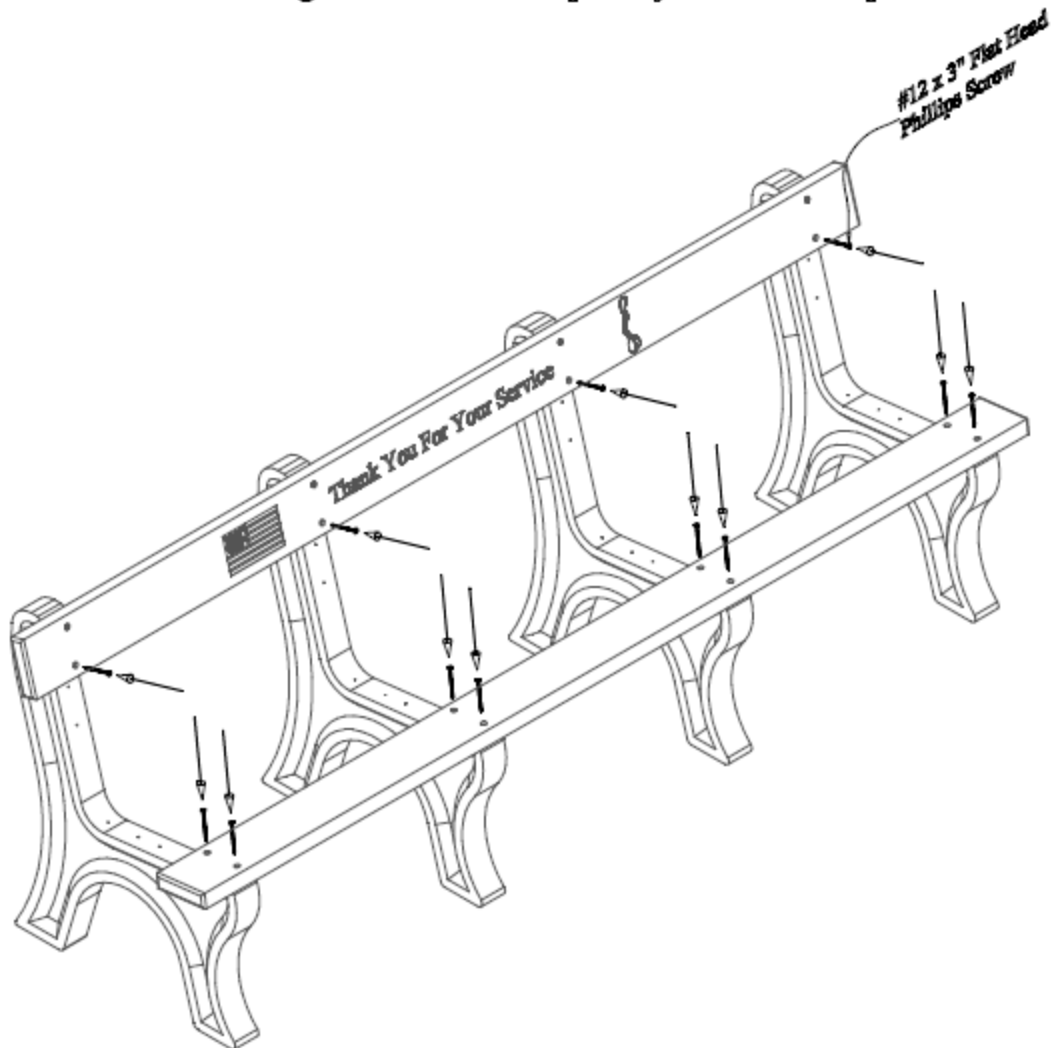

Step #4:

Place a second bench board on position 5. Repeat Steps 1 - 3 to attach. Use (1) One #12 x 3" Flat Head Phillips Screw per hole to fasten.

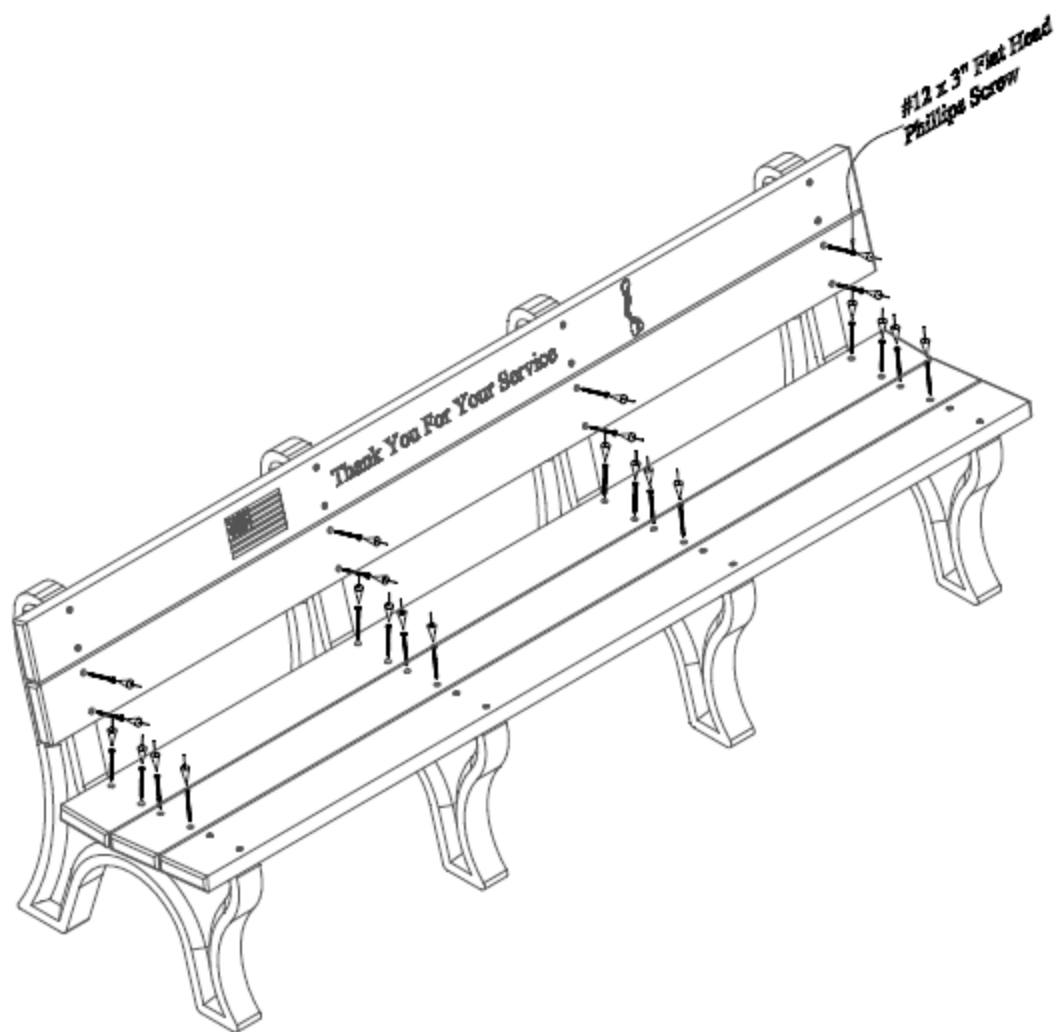

Step #5:

Repeat Steps 1 - 3 to attach bench boards on positions 2, 3 & 4. Use (1) One #12 x 3" Flat Head Phillips Screw per hole to fasten.