

Optional Bench Arm Assembly Instructions

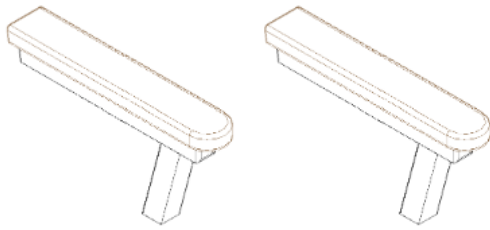

D - Bench Arm

D - Bench Arm

(2) - Two Bench Arms
BSA-DBA-A-00

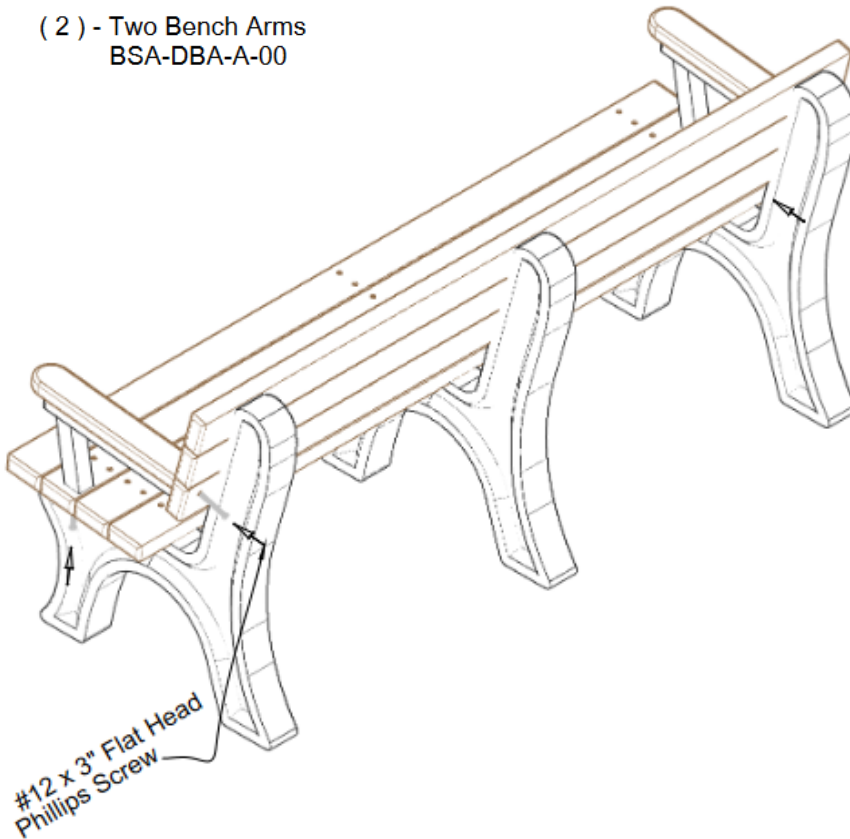

#12 x 3" Flat Head
Phillips Screw

Position the bench arms (Part D) as shown above. Align the pilot holes to the pre-drilled holes in the bench board w/ arm holes (Part C). After the holes are properly aligned, fasten with (1) One #12 x 3" Flat Head Phillips Screw per hole.