

ASSEMBLY AND MOUNTING INSTRUCTIONS
8 FOOT BENCH, OCCOUTDOORS, INC. GREENWOOD SERIES (GW-BEN-8)

PAGE 1

ASSEMBLY INSTRUCTIONS: BENCH 8 FOOT LENGTH 140201, 140202, and 140203

1. Unpack and lay out pieces to assemble. Verify that the parts, quantity and dimensions match those on the enclosed bill of material.
2. Begin by setting up two support frame weldments on a smooth, level surface roughly 86 inches apart on centers laying them on their back with “seat” in a “vertical” direction. Center the third weldment between them. See diagram 1.
3. Make marks on each plate at a distance of $2 \frac{7}{8}$, 7, and $11 \frac{1}{4}$ inches from the end of the plate. Diagram 2.
4. Locate one bull nose board on the first weldment at a distance of $3 \frac{1}{4}$ inches from end of the board to edge of weldment plate and flat edge on the $11 \frac{1}{4}$ inch mark. Make certain curved edge is facing bend in plate.
5. Clamp board to weldment and locate the middle weldment at distance of $46 \frac{1}{4}$ inches from end of board and the board flat edge on the $11 \frac{1}{4}$ inch mark. Clamp weldment to board. Use a hand square to align plates perpendicular to board. See diagram 2.
6. Locate the third weldment at distance of $89 \frac{1}{4}$ inches from end of board and the board flat edge on the $11 \frac{1}{4}$ inch mark. Clamp weldment to board. Use a hand square to align plates perpendicular to board. See diagram 2.
7. Drill $\frac{5}{32}$ diameter pilot hole (six) places) into the board and install six $\frac{1}{4}$ x 2 screws into the board. (use fourth line of 2 holes in metal plate of weldments as a drill guide)
8. Set one rectangular board at a distance of $3 \frac{1}{4}$ inches from plate side edge to end of board with flat edge on the 7 inch marks. Suggest placing a $\frac{3}{4}$ inch thick spacer between the bull nose and rectangular board at each end to maintain $\frac{3}{4}$ inch gap. Clamp board in place. See diagram 2.
9. Drill $\frac{5}{32}$ diameter pilot hole (six) places) into the board and install six $\frac{1}{4}$ x 2 screws into the board. (use third line of 2 holes in metal plate of weldment as a drill guide)
10. Set the second rectangular board at a distance of $3 \frac{1}{4}$ inches from plate side edge to end of board with flat edge of board on $2 \frac{7}{8}$ inch mark. Suggest placing a $\frac{3}{4}$ inch thick spacer between the two rectangular boards at each end to maintain $\frac{3}{4}$ inch gap. See diagram 2.
11. Drill $\frac{5}{32}$ diameter pilot hole (six places) into the board and install six $\frac{1}{4}$ x 2 screws through washers into the board. (use second line of 2 holes in metal plate of weldments as a drill guide)
12. Locate second bull nose board at a distance of $3 \frac{1}{4}$ inches from plate side edge to end of board and at a gap distance of $\frac{3}{4}$ inch between bull nose and rectangular board. Suggest placing a $\frac{3}{4}$ inch thick spacer between the bull nose and rectangular board at each end to maintain $\frac{3}{4}$ inch gap. See diagram 2.
13. Drill $\frac{5}{32}$ diameter pilot hole (six places) into the board and install six $\frac{1}{4}$ x 2 screws through washers into the board. (use first line of 2 holes in metal plate of weldments as a drill guide)
14. Check square ness of boards with plates with hand square before tightening screws.
15. Set the bench upright to fasten the boards on the back. See diagram 3.

DIAGRAM 1: BENCH 8 FOOT LENGTH SURFACE 140201, 140202 & 140203 SHOWN

140203

140202

140201

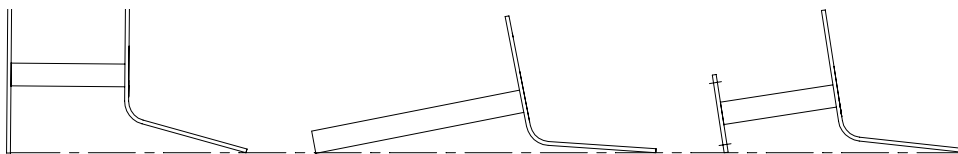

16. Make marks on each plate at a distance of $2\frac{7}{8}$, $7\frac{1}{8}$ inches from the end of the plate. Diagram 2
17. Locate one bull nose board on the weldments at a distance of $3\frac{1}{4}$ inches from end of the board to edge of weldment plate with flat edge of board on the $7\frac{1}{8}$ inch marks. Make certain curved edge is facing bend in plate. Clamp board in place. See diagram 3. **IMPORTANT: Make sure that the distance between the two bull nose boards where seat meets the back measures 4 inches or less. Adjust the board on the back to meet 4 inch maximum dimension.**
18. Drill $\frac{5}{32}$ diameter pilot hole (six places) into the board and install six $\frac{1}{4}$ x 2 screws into the board. (use third line of 2 holes in metal plate of weldments as a drill guide) Diagram 3.
19. Set one rectangular board at a distance of $3\frac{1}{4}$ inches from plate side edge to end of board with flat edge of board on the $2\frac{7}{8}$ inch mark. Clamp board in place. Suggest placing a $\frac{3}{4}$ inch thick spacer between the bull nose and rectangular board at each end to maintain $\frac{3}{4}$ inch gap. See diagram 3.
20. Drill $\frac{5}{32}$ diameter pilot hole (six places) into the board and install six $\frac{1}{4}$ x 2 screws into the board. (use second line of 2 holes in metal plate of weldments as a drill guide) Diagram 3.
21. Locate second bull nose board at a distance of $3\frac{1}{4}$ inches from plate side edge to end of board with a gap distance of $\frac{3}{4}$ inches between bull nose and rectangular boards at both ends. Suggest placing a $\frac{3}{4}$ inch thick spacer between the bull nose and rectangular board at each end to maintain $\frac{3}{4}$ inch gap. Clamp board in place. See diagram3.
22. Drill $\frac{5}{32}$ diameter pilot hole (four places) into the board and install four $\frac{1}{4}$ x 2 screws into the board. (use first line of 2 holes in metal plate of weldments as a drill guide) Diagram 3.
23. Check square ness of boards with plates before tightening all screws.

DIAGRAM 2: BENCH 8 FOOT LENGTH 140201 SHOWN (ATTACHING SEAT BOARDS)

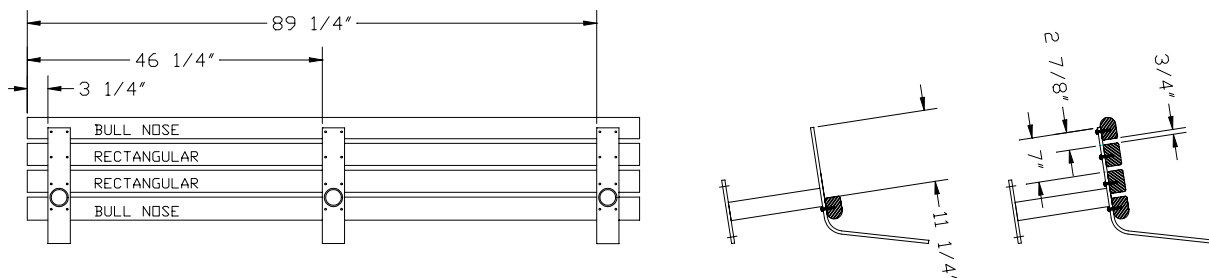
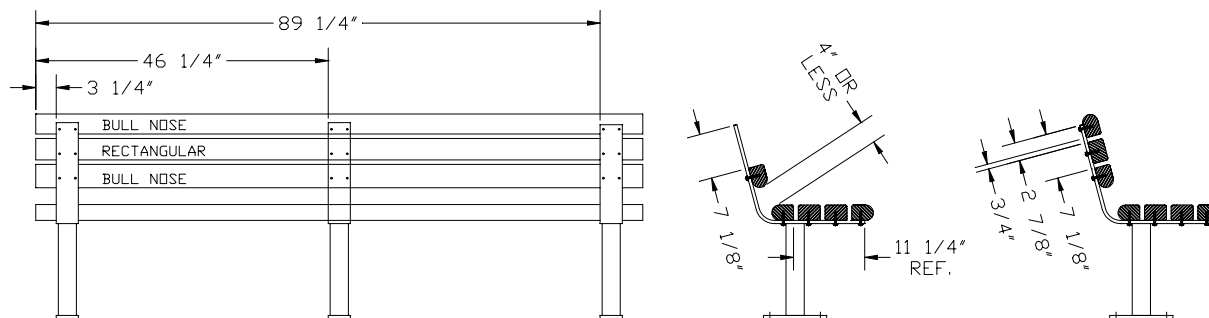

DIAGRAM 3: BENCH 8 FOOT LENGTH 140201 SHOWN (ATTACHING BACK BOARDS)



ASSEMBLY AND MOUNTING INSTRUCTIONS
 8 FOOT BENCH, OCCOUTDOORS, INC. GREENWOOD SERIES (GW-BEN-8)
 PAGE 3

MOUNTING INSTRUCTIONS: BENCH 8 FOOT LENGTH 140201, 140202, and 140203

1. Surface mount bench 140201 mounts with ½ inch anchors into concrete surface at dimensions as shown on diagram 3.
2. Embedded mount bench 140202 mounts by setting in filled holes at dimensions as shown on diagram 3.
3. Portable bench 140203 will rest on any flat, even surface-no mounting required

DIAGRAM 4: BENCH 8 FOOT LENGTH, SHOWN ARE
 SURFACE 140201 CONCRETE ANCHORS 6 PLACES
 EMBEDDED 140202 HOLES 3 PLACES
 PORTABLE 140203 NO MOUNTING

SURFACE 140201

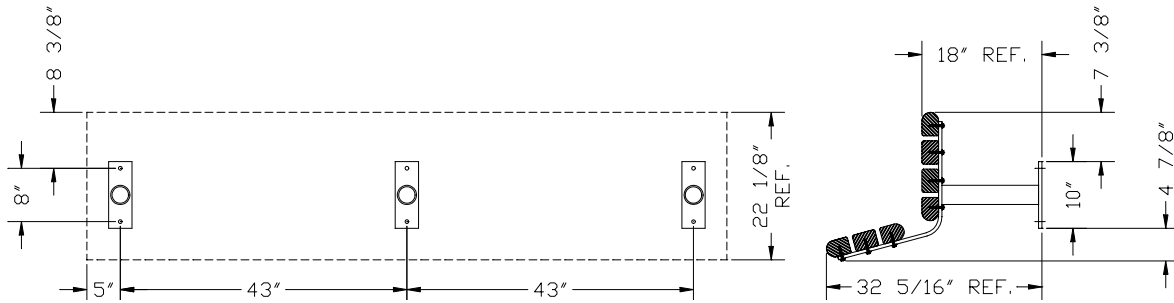

EMBEDDED 140202

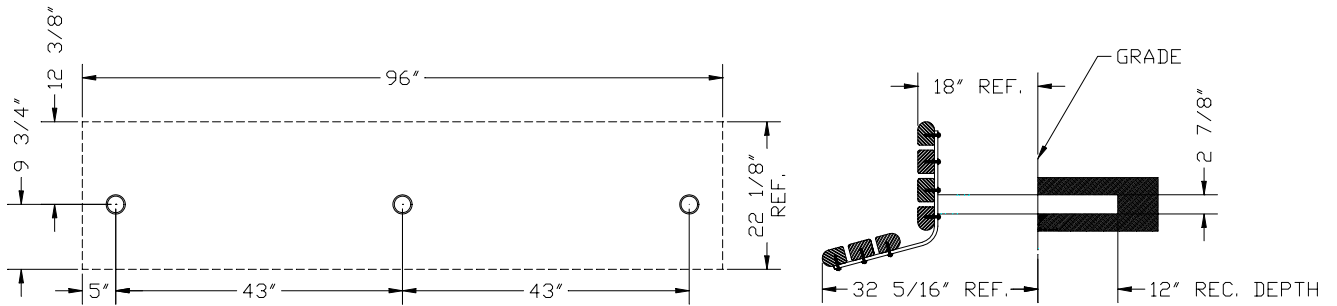

PORTABLE 140203

