

UP185 CHIN-UP

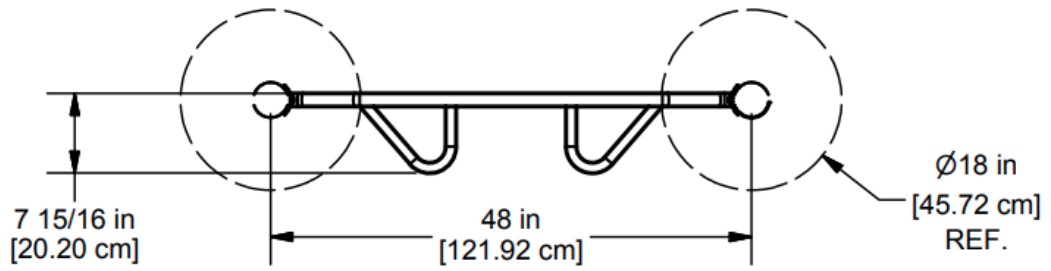

PLAN VIEW

CONCRETE REQUIRED:
.20 CUBIC YARDS
[.15 CUBIC METERS]

NOTE: Refer to Overall top view to determine High or Low installation.

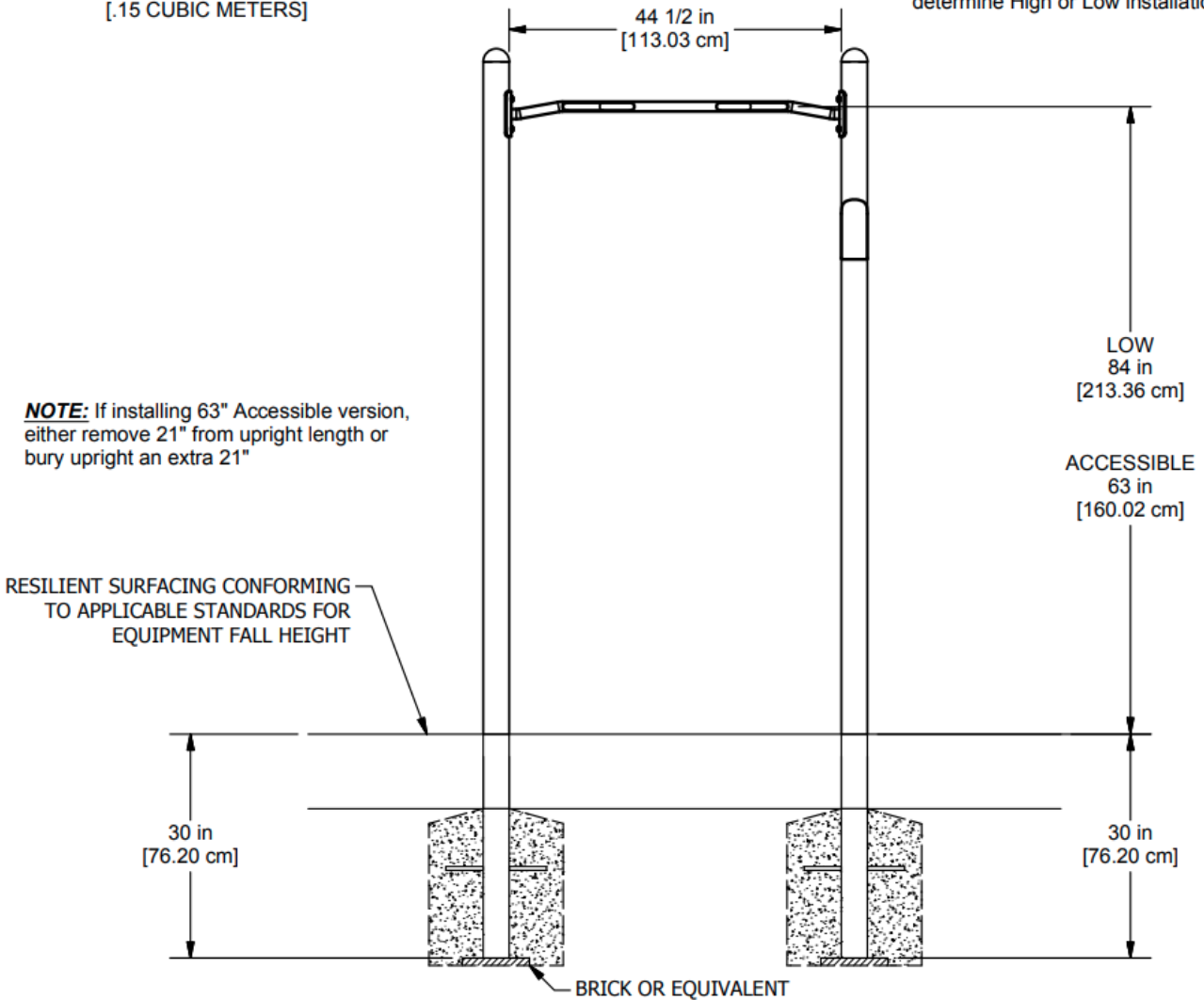

ELEVATION VIEW

SPECIFICATIONS:

CHIN-UP BAR: The Chin-Up Bar assembly shall be constructed of 1.315" O.D. (12 GA) galvanized pipe, 1.029 O.D. galvanized pipe and 3/16" stainless steel tabs. The Crossbar shall be an all welded construction and coated with a custom formula of TGIC polyester powder coating after fabrication.

HARDWARE: All nuts, bolts, screws, inserts, and lockwashers used in the assembly of all play equipment, shall be stainless steel, yellow dichromate plated steel, blue-coat plated steel, mechanically galvanized or powder coated/yellow dichromate plated steel. All primary fasteners shall be 300 series stainless steel. Fasteners with yellow dichromate treatment have an electro deposited, 99.9% pure zinc substrate applied from a specially formulated solution sealed with a yellow dichromate top coat designed to work in conjunction with the zinc plating. Yellow dichromate has a 320% longer life to white corrosion and 275% longer to red corrosion than does hot-dip galvanizing.

INSTALLATION INSTRUCTIONS:

1. Dig footing holes as shown in Plan and Elevation Views. Place brick or equivalent in the bottom of hole to provide a solid foundation.

NOTE: If installing 63" Accessible version, either remove 21" from upright length or bury upright an extra 21"

2. Attach the Chin-Up Bar to the Uprights using 3/8" x 1 1/4" P.B.H.C.S. w/Patch, 3/8" Lockwasher. See detail 086. After all bars are in place, set legs in the holes. Level all legs and cross bars and support them with wood or wire guides until the unit is ready for use. Be sure each leg is standing on a solid foundation block.
3. Attach the Chin-Up Name Plate to the Upright using Pop Rivet. See Detail 322.
4. Attach 1/2" Anchor Rod to Upright. See detail 231.
5. Plumb and level the entire assembly and tighten all fasteners.
6. After entire unit is assembled, pour concrete footings within 4" to the top and taper away from posts for water drainage. Allow to cure at least 48 hours before use. Note: Temporary bracing may be required until concrete cures.
7. When the structure is finished and satisfactory, eliminate sharp points and sharp edges (burring) on installed hardware like bolts, nuts, etc.

Parts List		
DESCRIPTION	QTY	PART NUMBER
CHIN-UP BAR	1	206981
UPRIGHT	2	GRR4LJ
HARDWARE COMPLETE	1	403484
1/2" ANCHOR ROD	2	135038*
3/8" x 1 1/4" B.H.C.S.	4	811051*
3/8" LOCKWASHER	4	817334*
USAGE/WARNING LABEL	1	403879*

Unless Otherwise Specified, All Units of Measure are Each

**Items listed below Hardware Complete line are included with Hardware Complete Number*

Warning: During Installation, Hardware And Small Parts Are Choking Hazards For Young Children. Store Unused Parts Appropriately Until Assembly Is Completed. Once Assembly Is Completed, Remove Any Unused Parts From The Play Environment And Dispose/Save Them In A Secure Location. Any bolt end protruding more than two full threads beyond the face of the nut causes risk of clothing entanglement.

Promptly cut-off flush, file smooth, and treat to prevent corrosion.

Note: Peen Tee-Nuts and Flatwashers to match radius of pipe after assembly is complete.

Note: Loctite (supplied by others) should be used on any non-patch hardware.

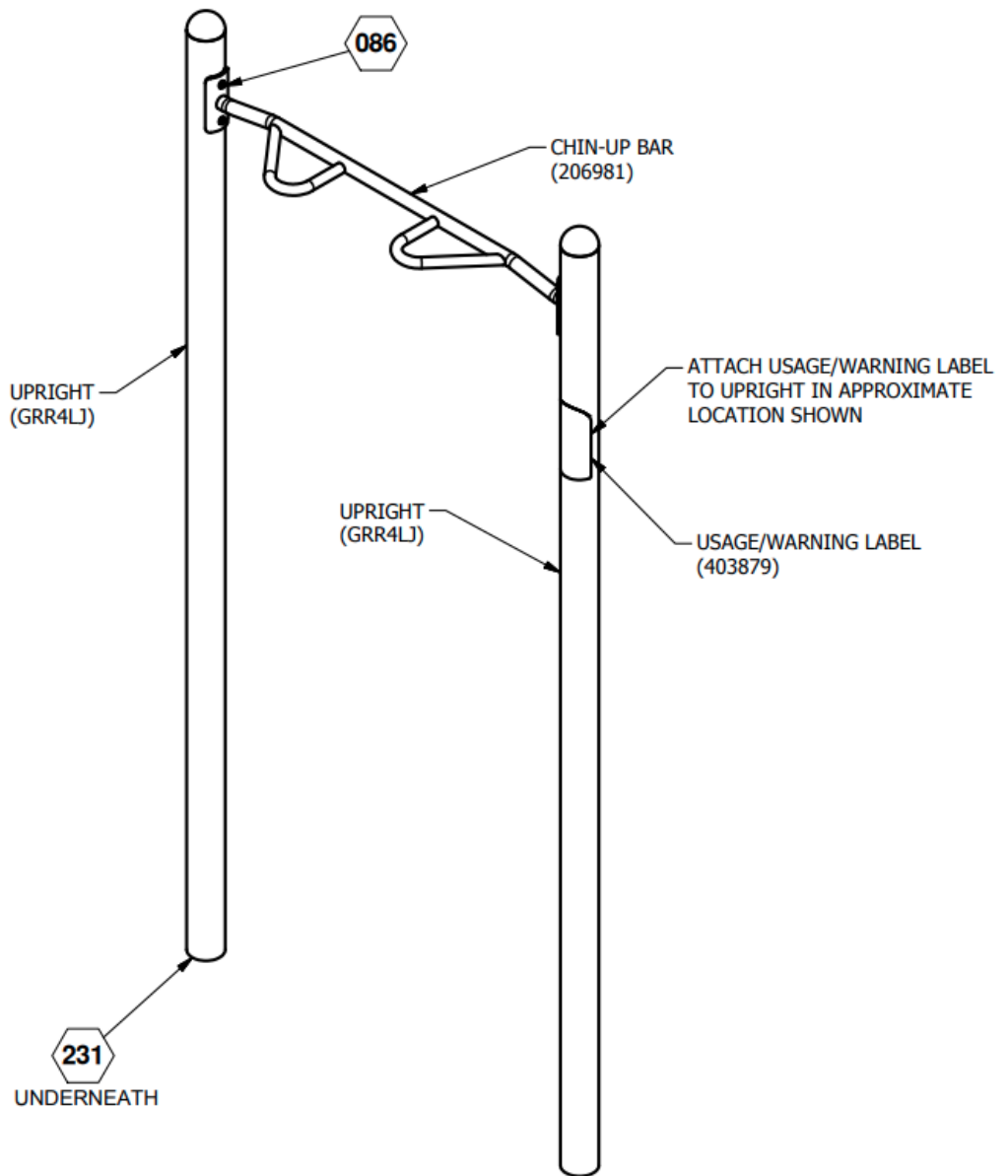

 = INSTALLATION DETAIL

FINISHED ASSEMBLY

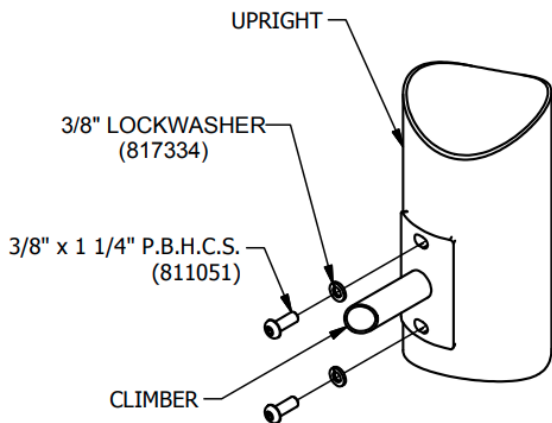

086

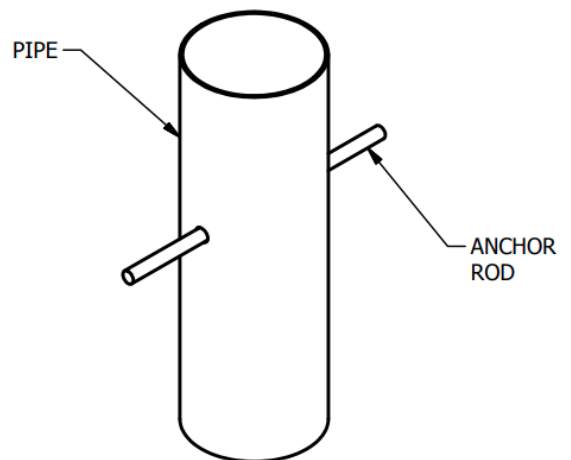

231

UP185 CHIN-UP

MAINTENANCE PROCEDURE:

Periodically check hardware for tightness, and tighten as necessary. Always check all parts for breakage or wear, and immediately put equipment out of service until any faulty parts found are repaired or replaced. Also Check all metal parts for rust, paint loss and touch-up if necessary with paint. Check for welded areas and verify integrity. Check periodically resilient surfacing for appropriate depth and remove extraneous materials that could cause injury, infection, or disease. Maintain detailed installation, inspection, maintenance, and repair records for each public-use playground equipment.



(317) 223-8881

occontact@occoutdoors.com