

6 Foot Park Classic Bench

For Fastener Pack
(FP-PC6B-CU-01)

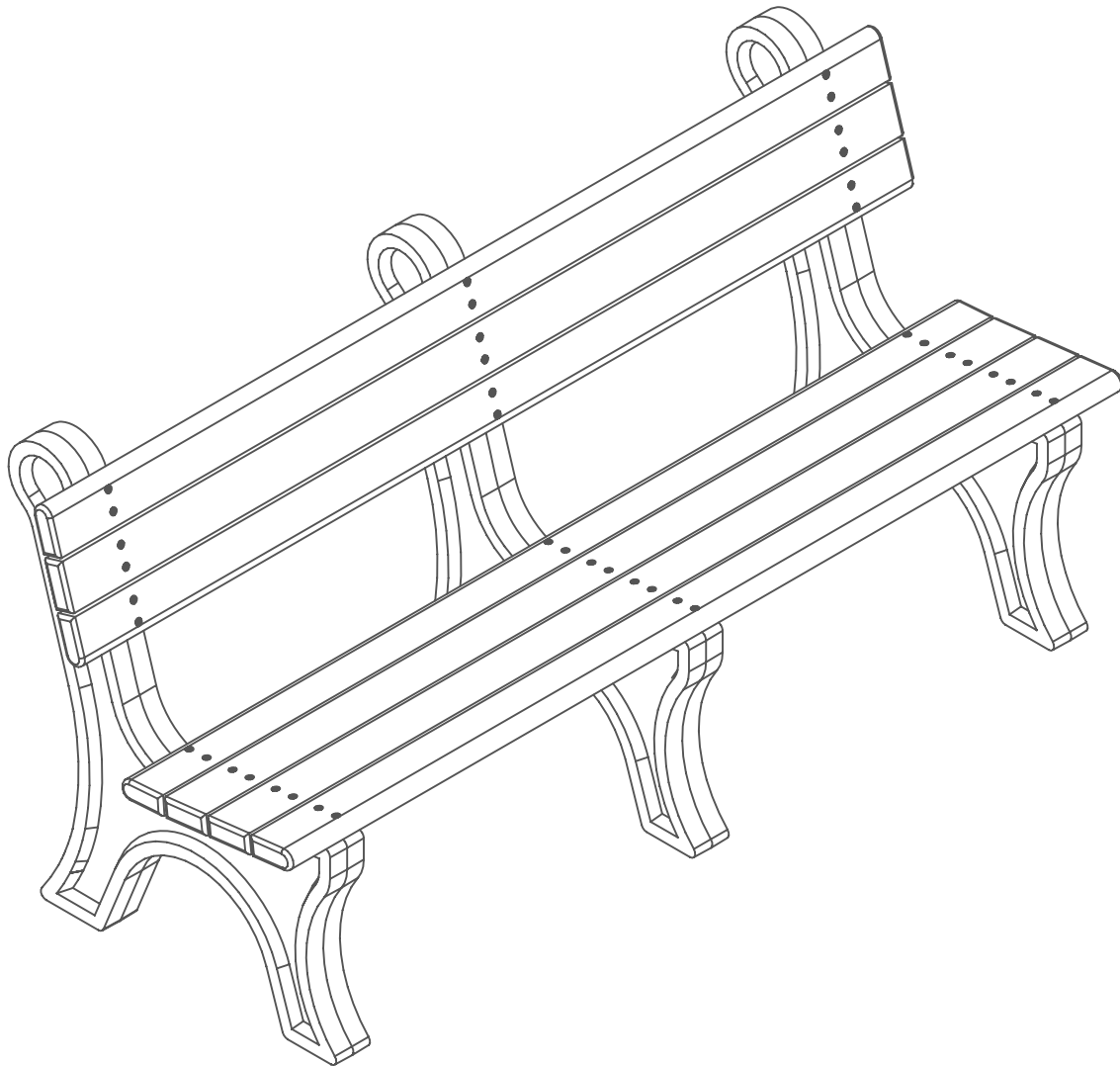

Congratulations !!

You have just purchased the finest recycled plastic
park bench available. Enjoy !!!

Before assembly, please make sure all components are included.



(1) - One Fastener Pack
FP-PC6B-CU-01

FP - Fastener Pack

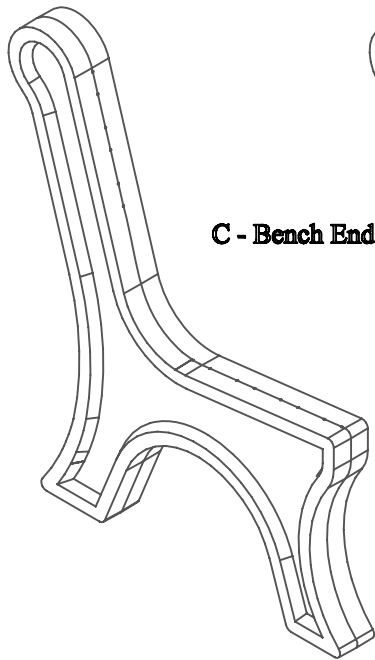

C - Bench End

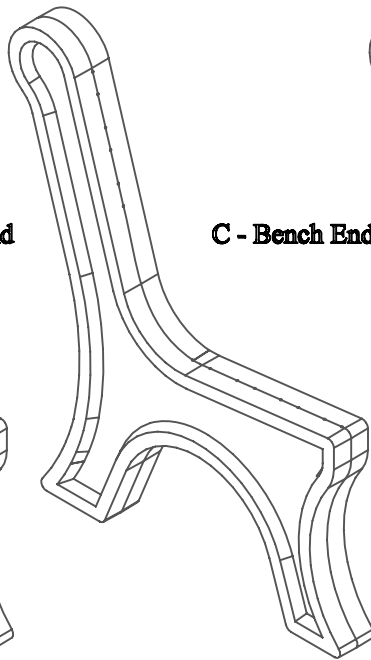

C - Bench End

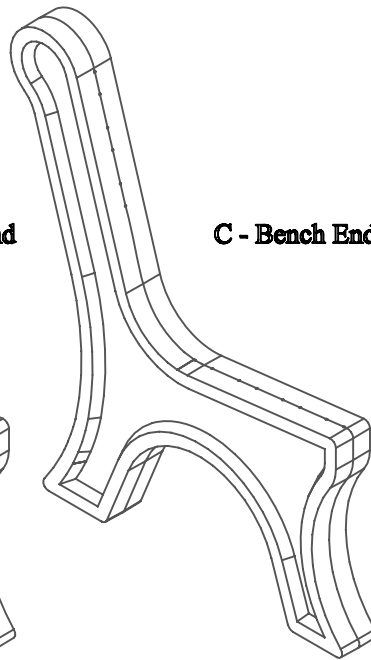

C - Bench End

(3) - Three Bench Ends
PS-BTBE-A-01

| | | | |
|---|-----------------|---|---|
| • | A - Bench Board | • | • |
| • | A - Bench Board | • | • |
| • | A - Bench Board | • | • |

(3) - Three Bench Boards
BP-DB6B-A-02

| | | | |
|---|---------------------------|---|---|
| • | B - Bull Nose Bench Board | • | • |
| • | B - Bull Nose Bench Board | • | • |
| • | B - Bull Nose Bench Board | • | • |
| • | B - Bull Nose Bench Board | • | • |

(4) - Four Bull Nose
Bench Boards
BP-PC6B-A-01

Before assembly, please make sure all fasteners are included.

42 - #12 x 3" Flat Head Phillips Screw

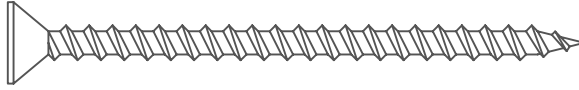

Also needed for this assembly will be the following materials:

1 - #3 Phillips Drive Bit

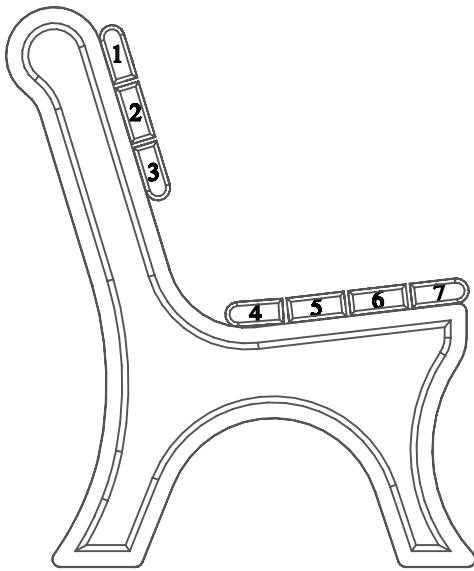
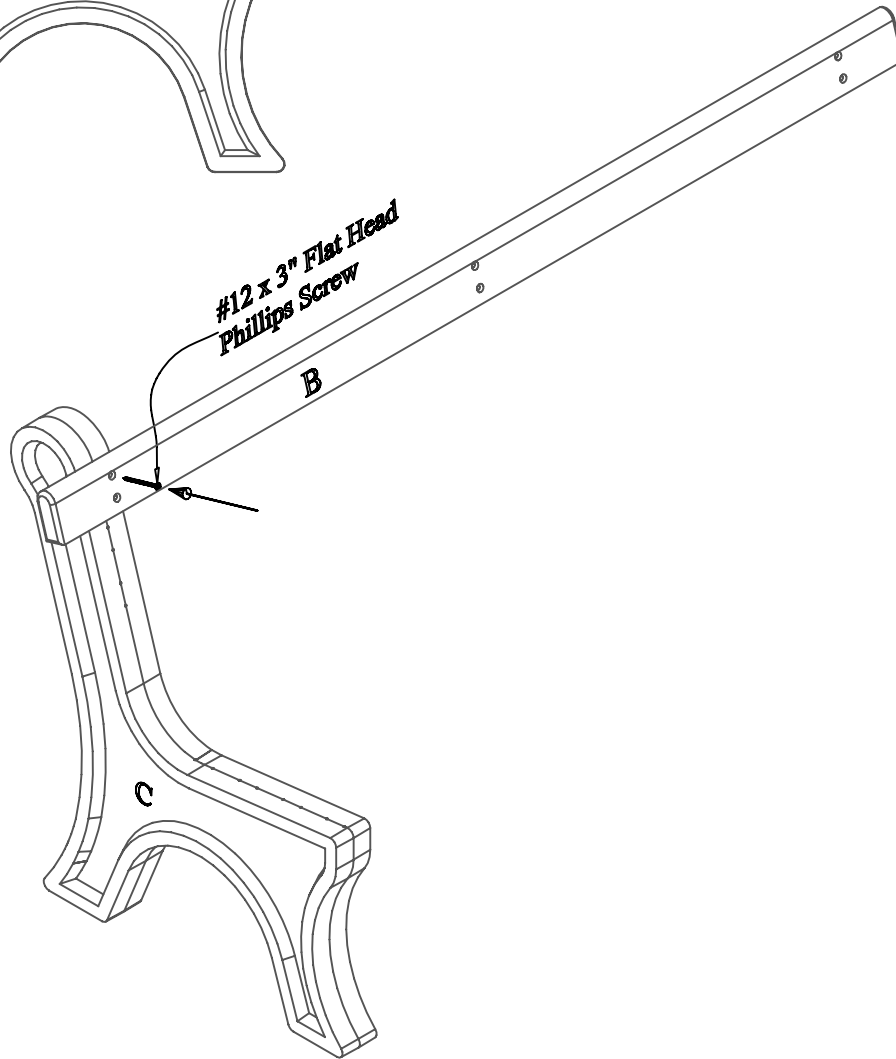

Fig #1:

In order to make the assembly of this Park Classic Bench easier while going through the assembly process the board positions are numbered and will be referenced in later steps.



Step #1:

Stand (1) One bench end upright and place (1) One bull nose bench board as shown above in position 1 being sure to align the pre-drilled holes to the pilot holes in the bench end. After the holes are properly aligned, fasten with (1) One #12 x 3" Flat Head Phillips Screw in the top pre-drilled hole.

Note: Do not tighten screw completely. This will be done in a later step.

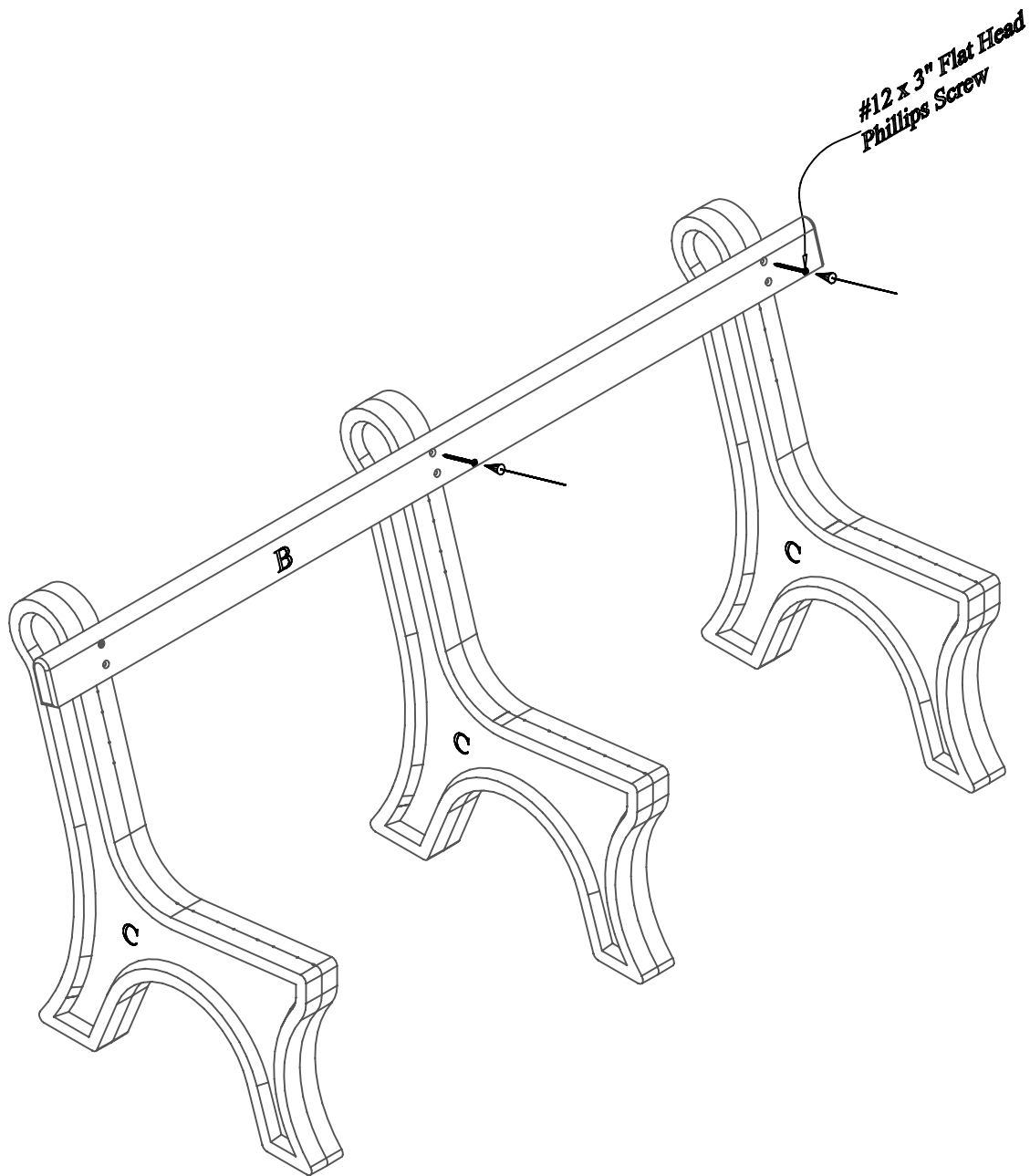

Step #2:

Stand the other (2) Two bench ends upright, one at a time, and place the bench board already attached to the first bench end, on position 1 being sure to align the pre-drilled holes to the pilot holes in the bench end. After the holes are properly aligned, fasten with (1) One #12 x 3" Flat Head Phillips Screw in the top pre-drilled hole.

Note: Do not tighten screws completely. This will be done in a later step.

Step #3:

Align the bottom pre-drilled holes to the pilot holes in the bench end. After the holes are properly aligned, fasten with (1) One #12 x 3" Flat Head Phillips Screw per hole.

Note: Be sure to tighten screws completely after this step.

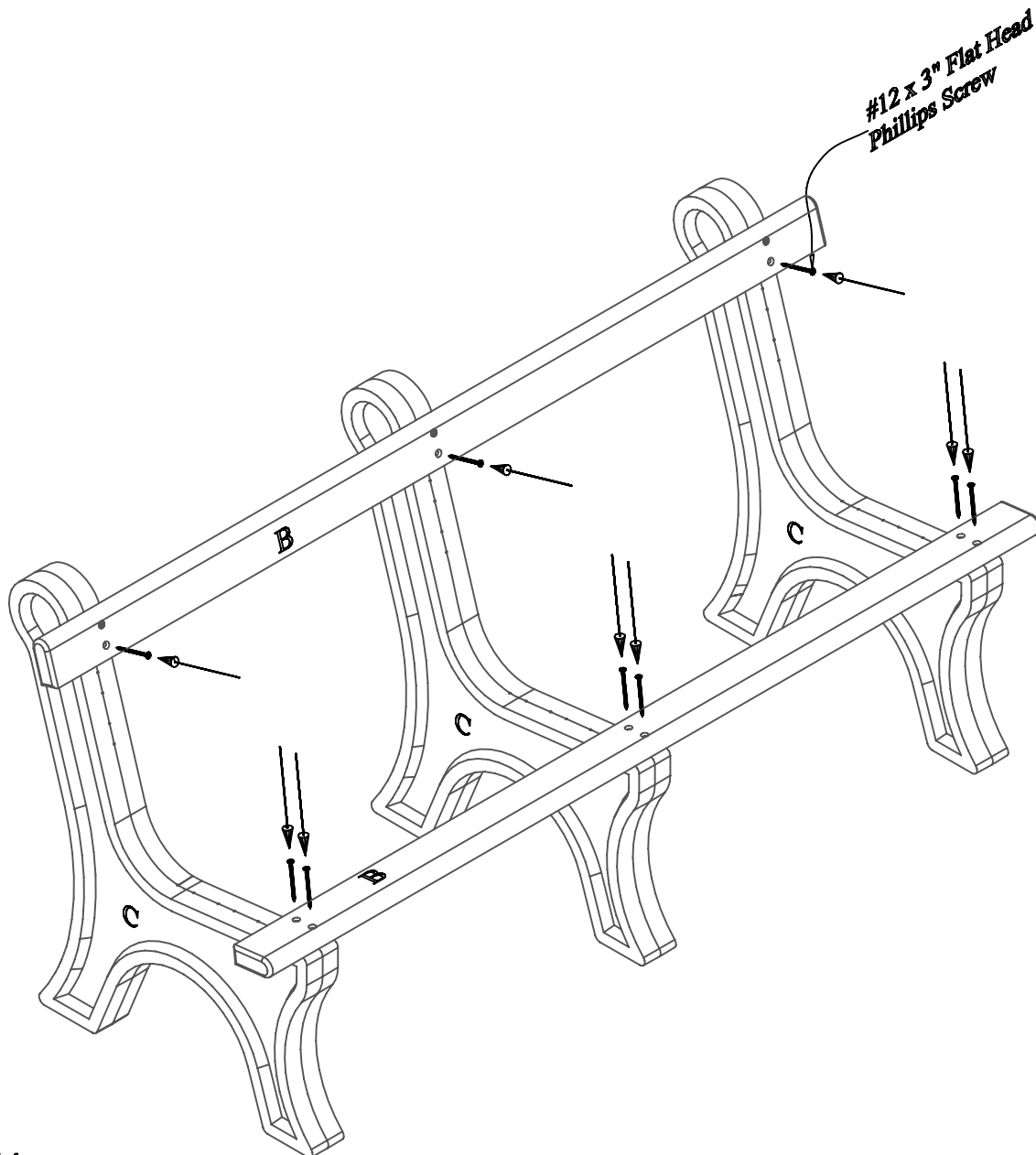

Step #4:

Place a second bull nose bench board on position 7 as shown above. Repeat Steps 1 - 3 to attach. Use (1) One #12 x 3" Flat Head Phillips Screw per hole to fasten.

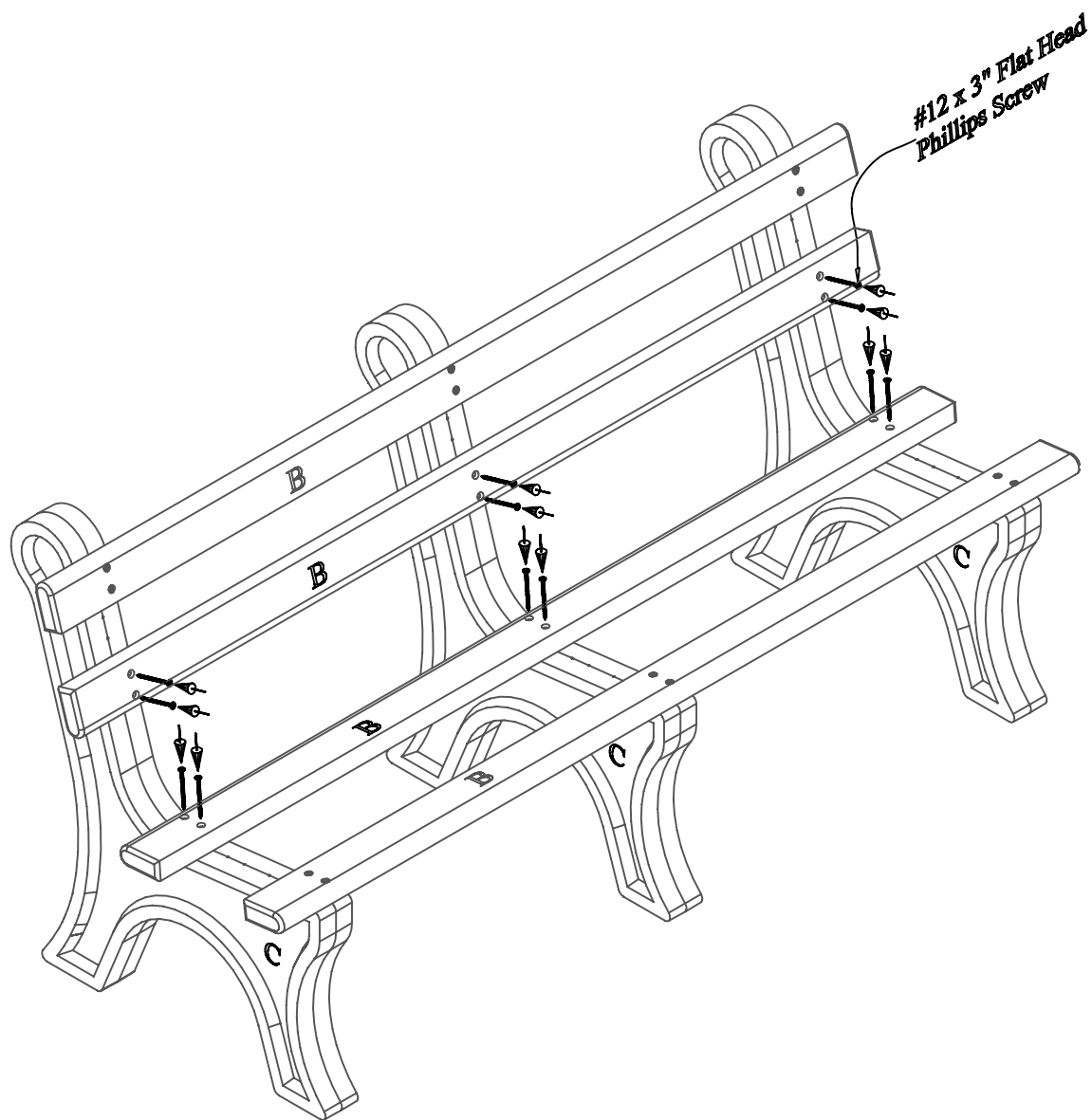

Step #5:

Repeat Steps 1 - 3 to attach bull nose bench boards on positions 3 & 4 as shown above. Use (1) One #12 x 3" Flat Head Phillips Screw per hole to fasten.

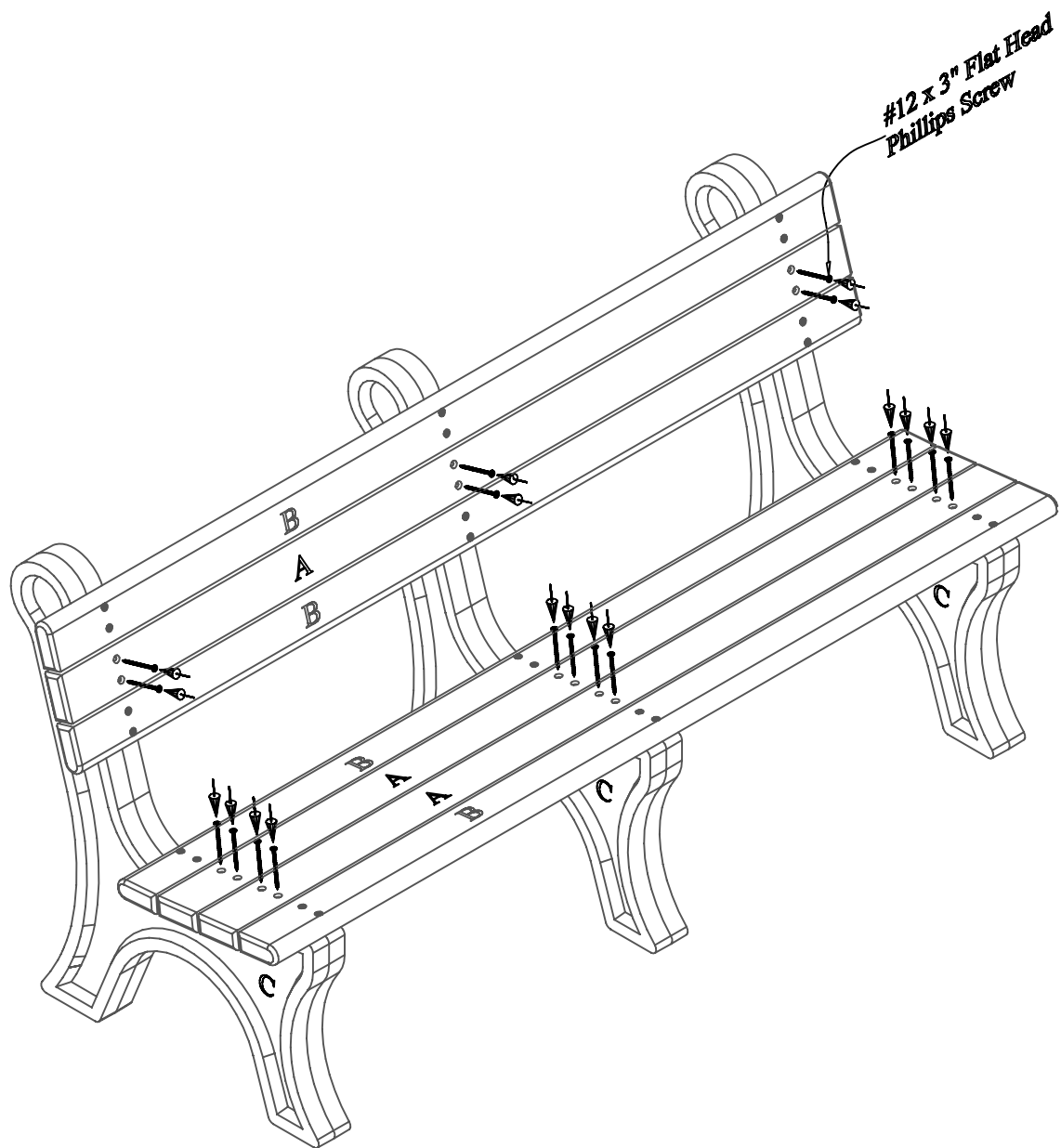

Step #6:

Repeat Steps 1 - 3 to attach bench boards on positions 2, 5 & 6. Use (1) One #12 x 3" Flat Head Phillips Screw per hole to fasten.