

Polly Tuff Easy Access Handi-cap Picnic Table

For Fastener Pack
(FP-PTEAHA-CU-01)

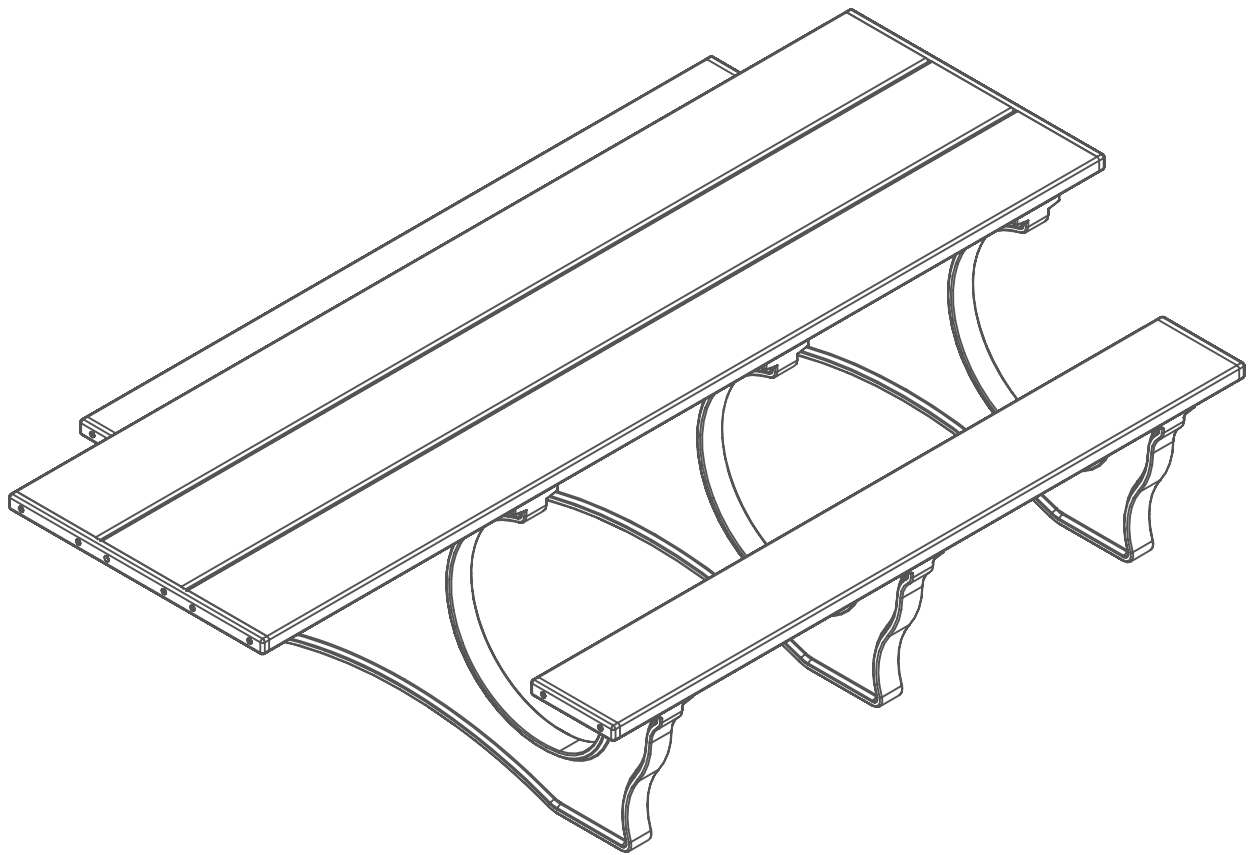

Congratulations !!

You have just purchased the finest recycled plastic
picnic table available. Enjoy !!!

Before assembly, please check to make sure all components are included.

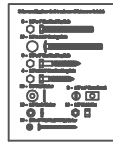

(1) - One Fastener Pack
FP-PTEAHA-CU-01

FP - Fastener Pack

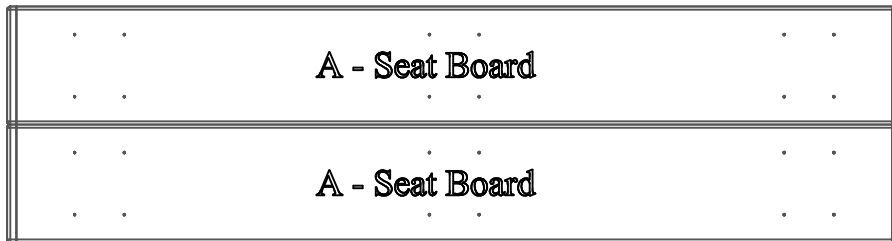

(2) - Two Seat Boards
STSA-EAHA-A-01

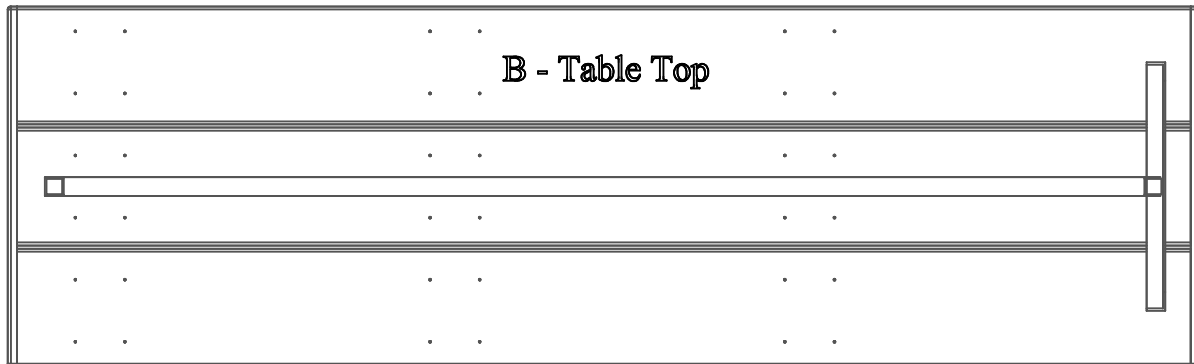

(1) - One Table Top
STSA-EAHA-B-01

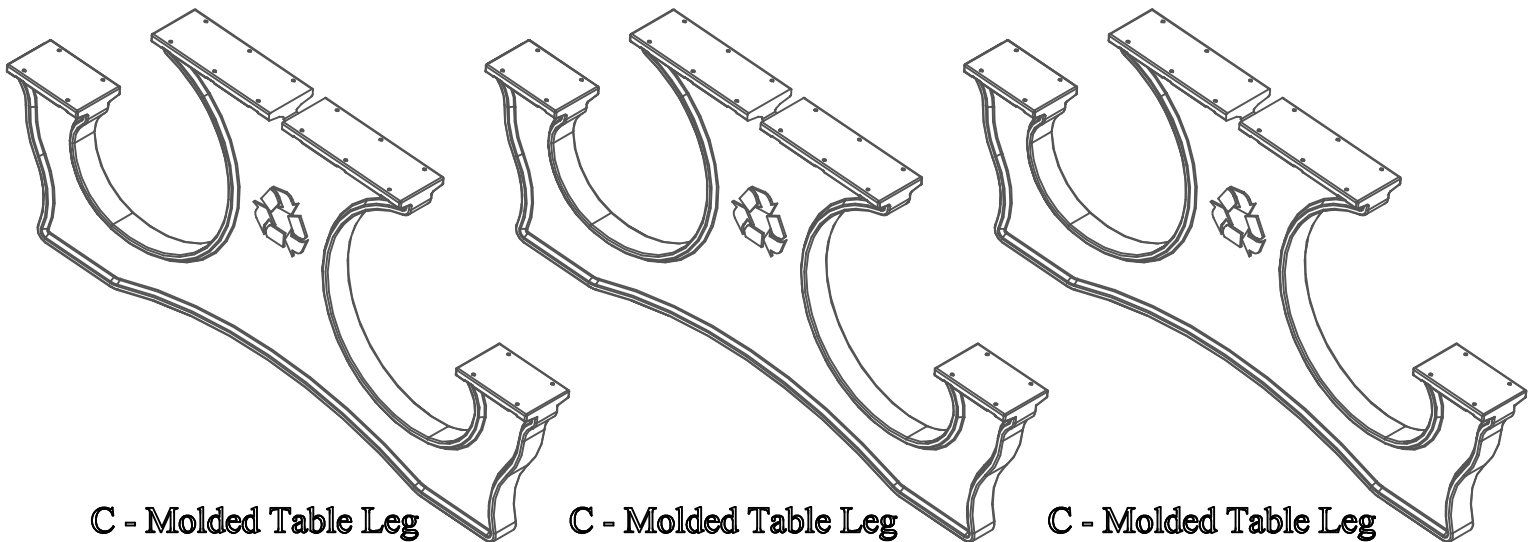

(3) - Three Molded Table Legs
PS-EA-HA-01

Before assembly, please check to make sure all fasteners are included.

60 - 1/4" x 1-3/4" Hex Head Lag Bolt

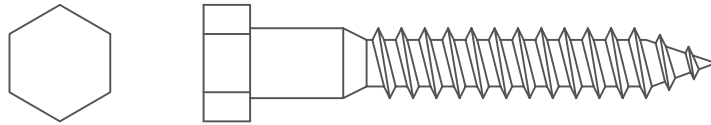

60 - 1/4" Flat Washer

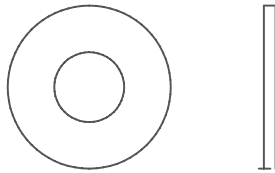

Note: It is recommended you use a impact driver or a screw gun.

Also needed for this assembly will be the following materials:

(1) - 7/16 " Socket Wrench or 7/16" Box End Wench

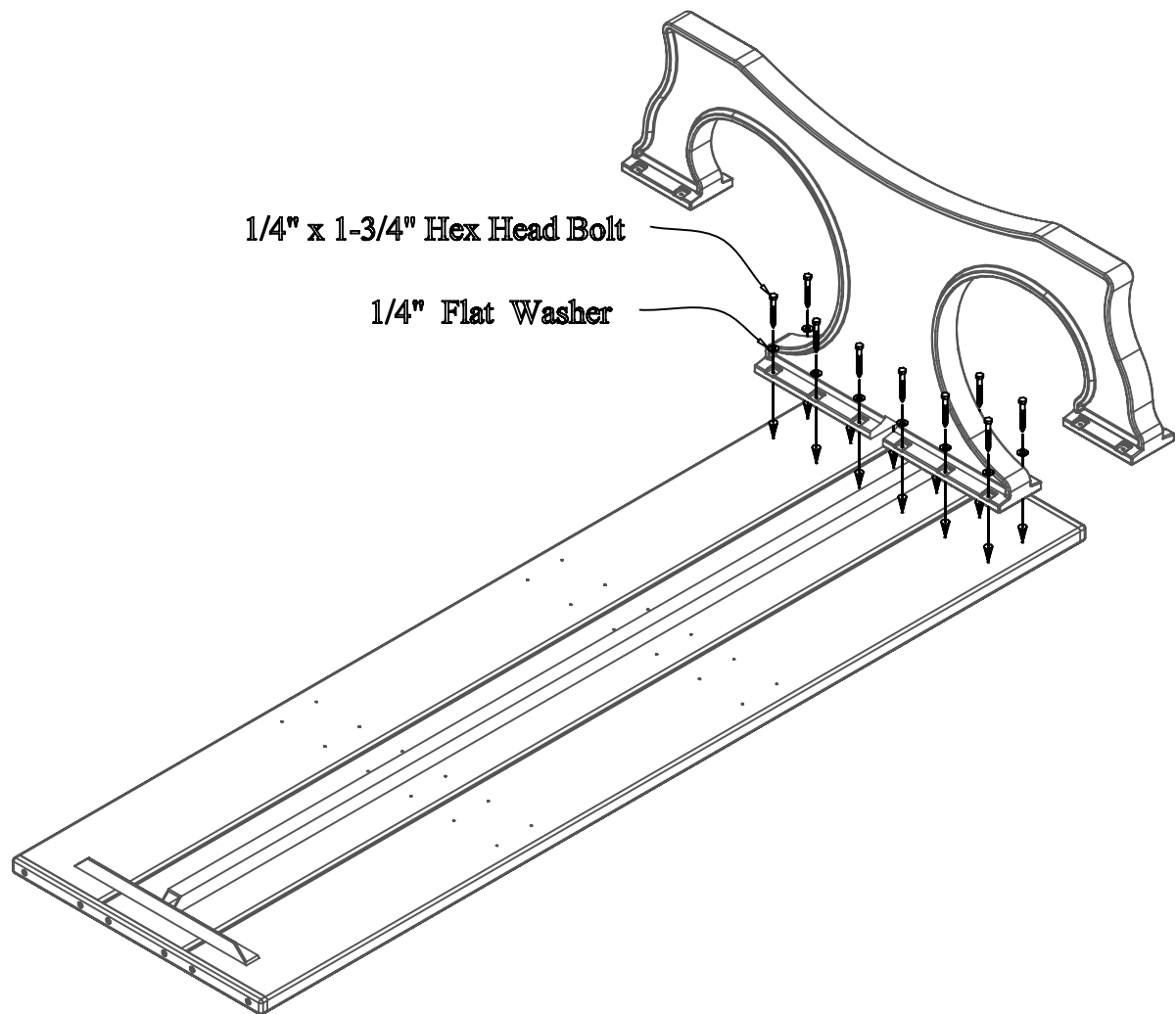

Step: #1

Place the Table Top assembly upside down onto a piece of cardboard or another soft level surface to protect it during installation. Place one Molded Leg on the Table top as shown above. Align the pre-drilled holes in the Molded Leg with the pilot holes in the Table top. Use (1) One 1/4" x 1-3/4" Lag Bolt and (1) - One 1/4" Flat Washer per hole to secure.

Note: Do not tighten bolts completely. This will be done in a later step.

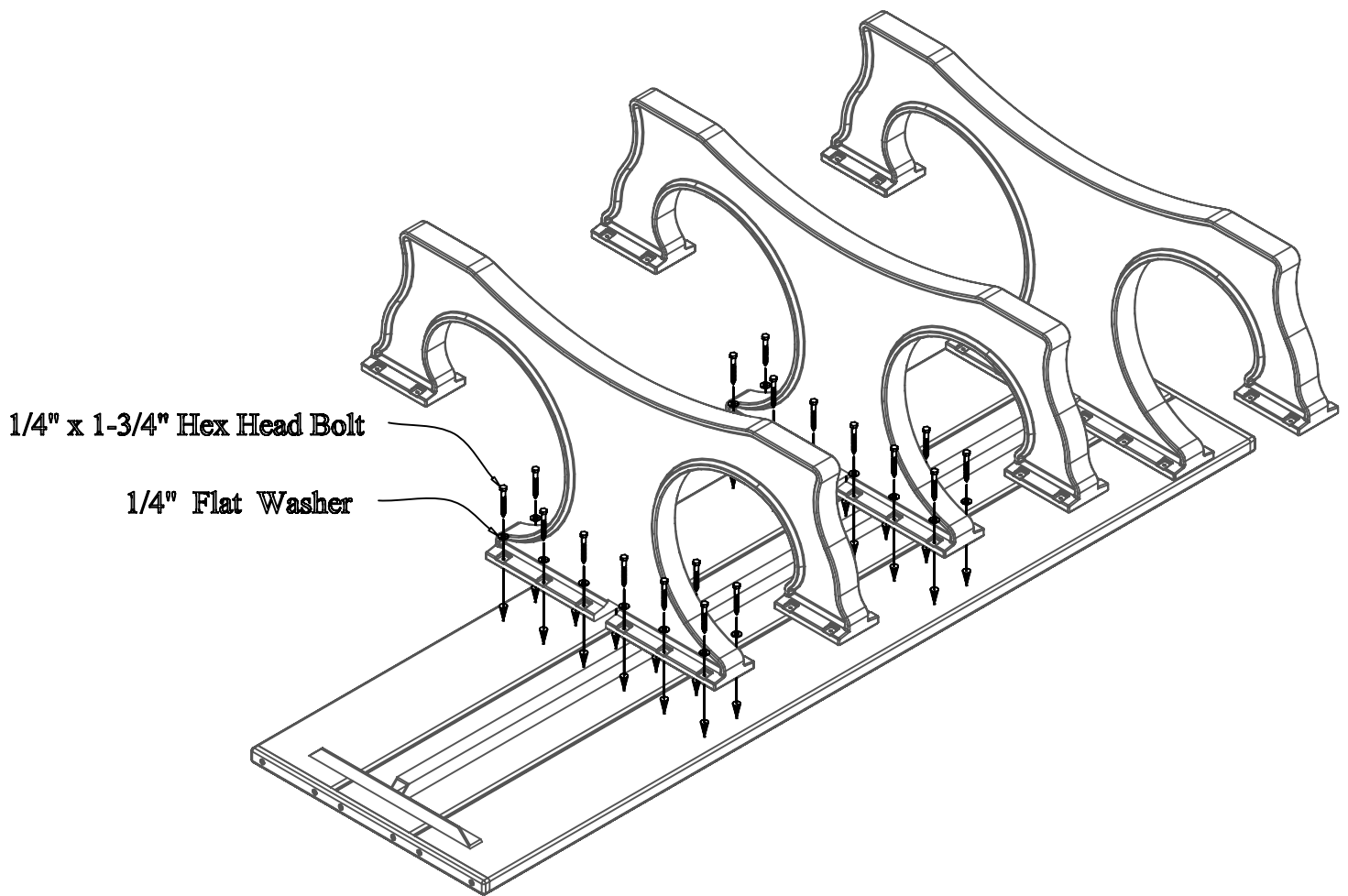

Step: #2

Place the remaining Molded Table Legs in position as shown above being sure to align the pre-drilled holes to the pilot holes in the Table top. After the holes are properly aligned, fasten with (1) - One 1/4" x 1-3/4" Lag Bolt and (1) - One 1/4" Flat Washer per hole to secure.

Note: Do not tighten bolts completely. This will be done at a later step.

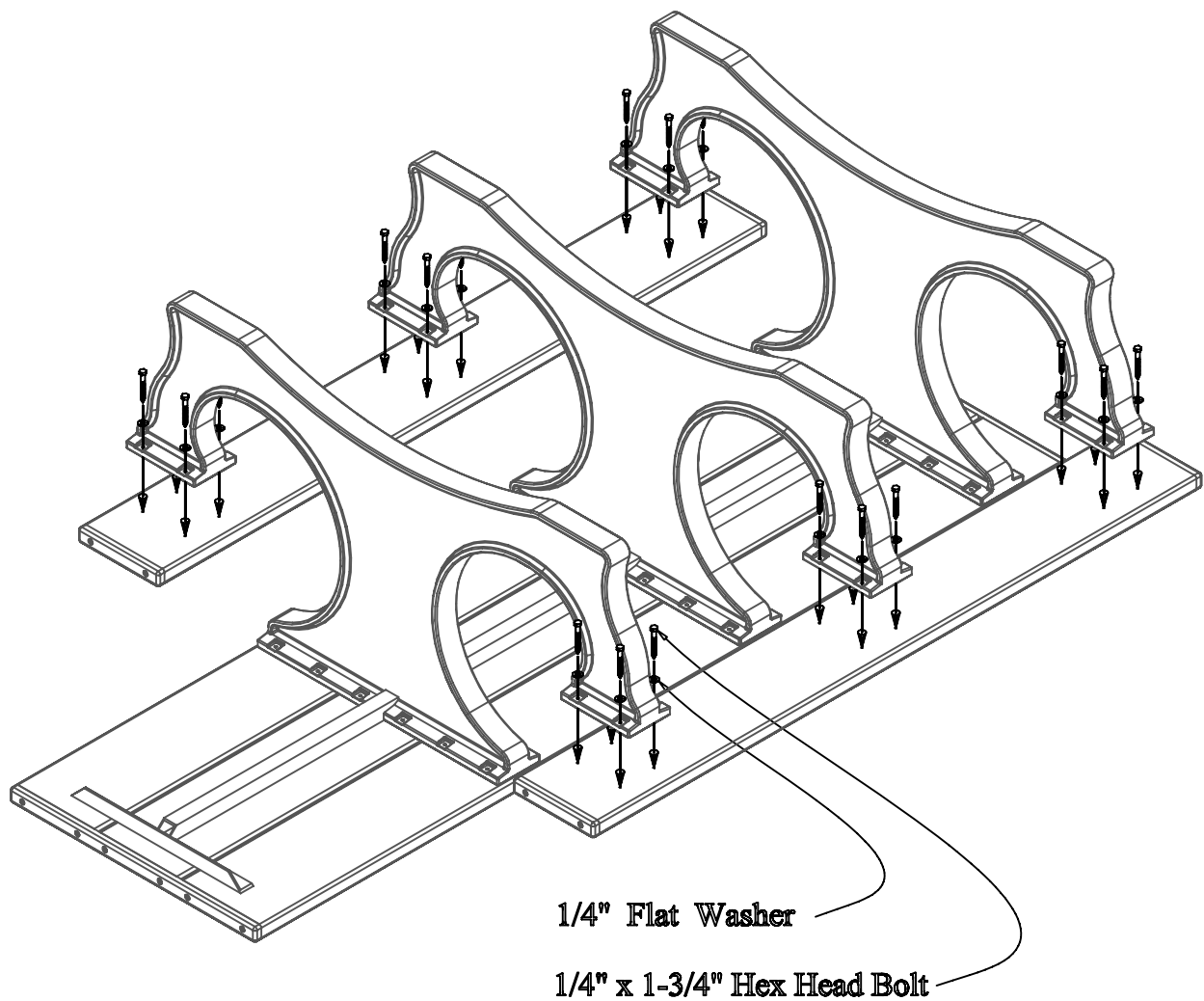

Step:#3

Place the Seat Boards in position as shown above being sure to align the pilot holes to the pre-drilled holes in the Molded Table Legs. After the holes are properly aligned, fasten with (1) - One 1/4" x 1-3/4" Lag Bolt and (1) - One 1/4" Flat Washer per hole to secure.

Note: Be sure to tighten all fasteners after completing this step. Please use caution to not over tighten the fasteners.