

Model # BARK-954-W6

HARDWARE

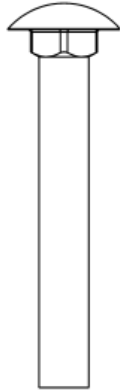

5/16" x 2 1/4"
Carriage Bolt

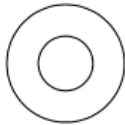

5/16" Washer



5/16" Hex Nut

TOOLS REQUIRED

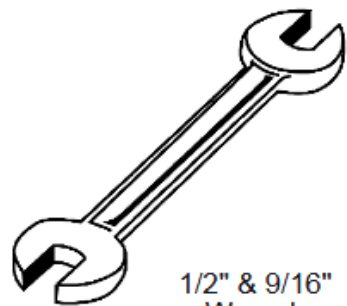

1/2" & 9/16"
Wrench



1/2" & 9/16"
Socket Wrench

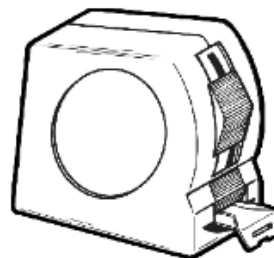

Tape Measure

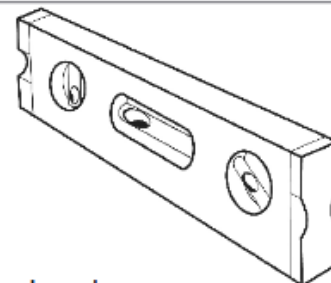

Level

BARK PARK PRODUCT SPECIFICATIONS

BARK-954-W6

Seats: Seats dimensions are 18" x 20" x 72". 12 gauge die formed flat steel plate with laser cut design. End plates are made of 10 gauge flat steel plate. Reinforced with 3/16 x 1-1/2" flat strip. Electrically MIG welded.

Frame: Legs are cast aluminum

Seat & Frame

Coating: Oven fused functionalized polyethylene copolymer-based thermoplastic. Fluidized bed coating application with superior mechanical performance, impact resistance and UV-stability.

Hardware: All stainless steel hardware fasteners.

Dimensions: 6' portable/surface mount bench with back. Seats are 18" wide x 72-1/8" long. Seat height is 18" from the ground to the top of the seat. The overall dimensions are 76" x 23" x 35"

COMPONENTS

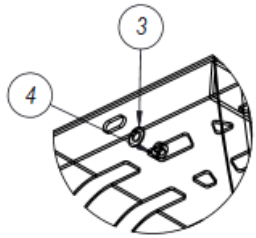

DETAIL A
SCALE 1 : 6

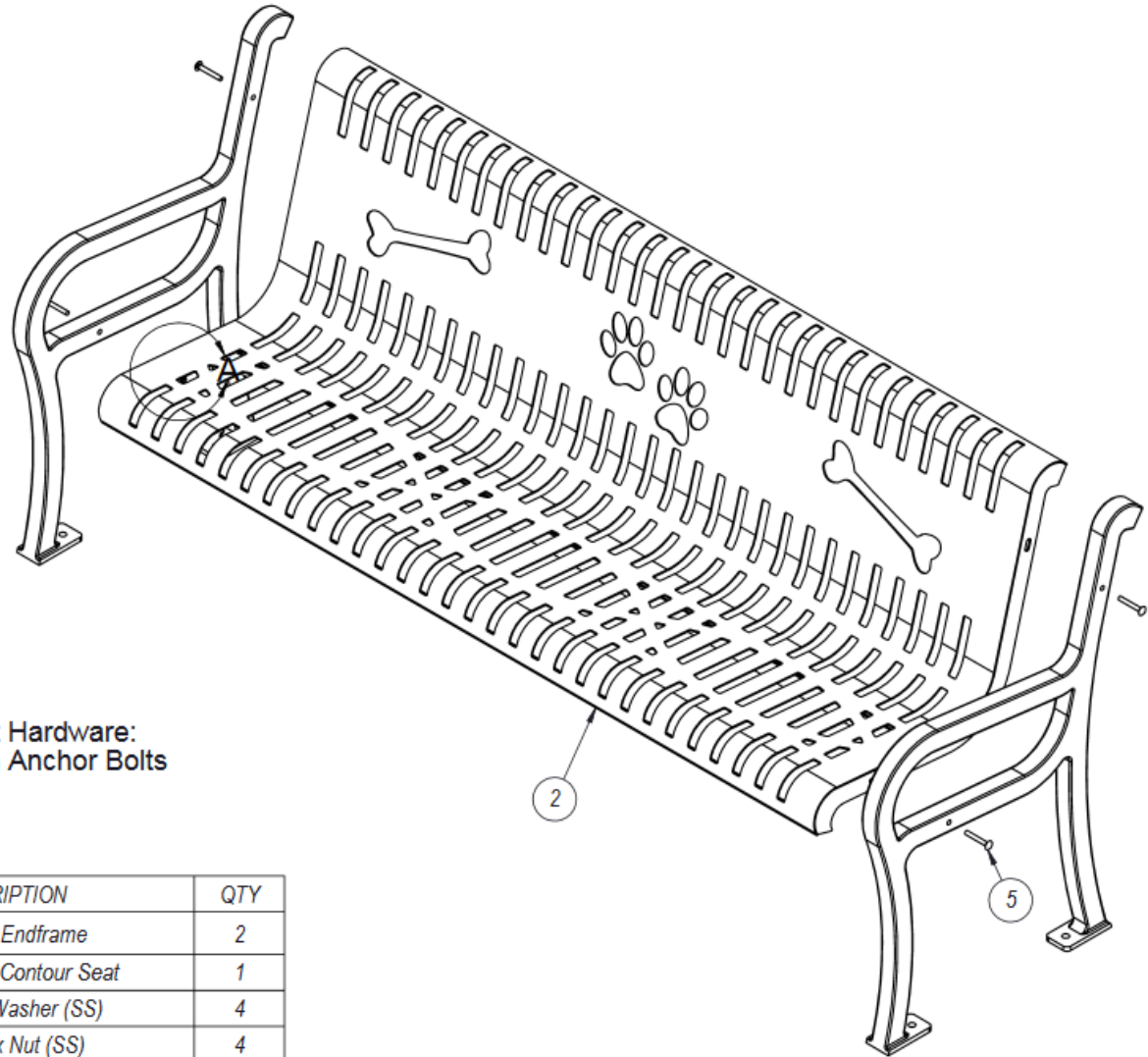

Recommended Surface Mount Hardware:
3/8" x 3 1/2" Concrete Expansion Anchor Bolts

ITEM NO.	PartNo	DESCRIPTION	QTY
1	T-11-01-CAST	954 Cast Endframe	2
2	T-01-08-0049	6' Bark Park Contour Seat	1
3	33-02-0007	5/16" Flat Washer (SS)	4
4	33-03-0009	5/16" Hex Nut (SS)	4
5	33-06-0053	5/16" x 2-1/4" Carriage Bolt (SS)	4

STEP 1

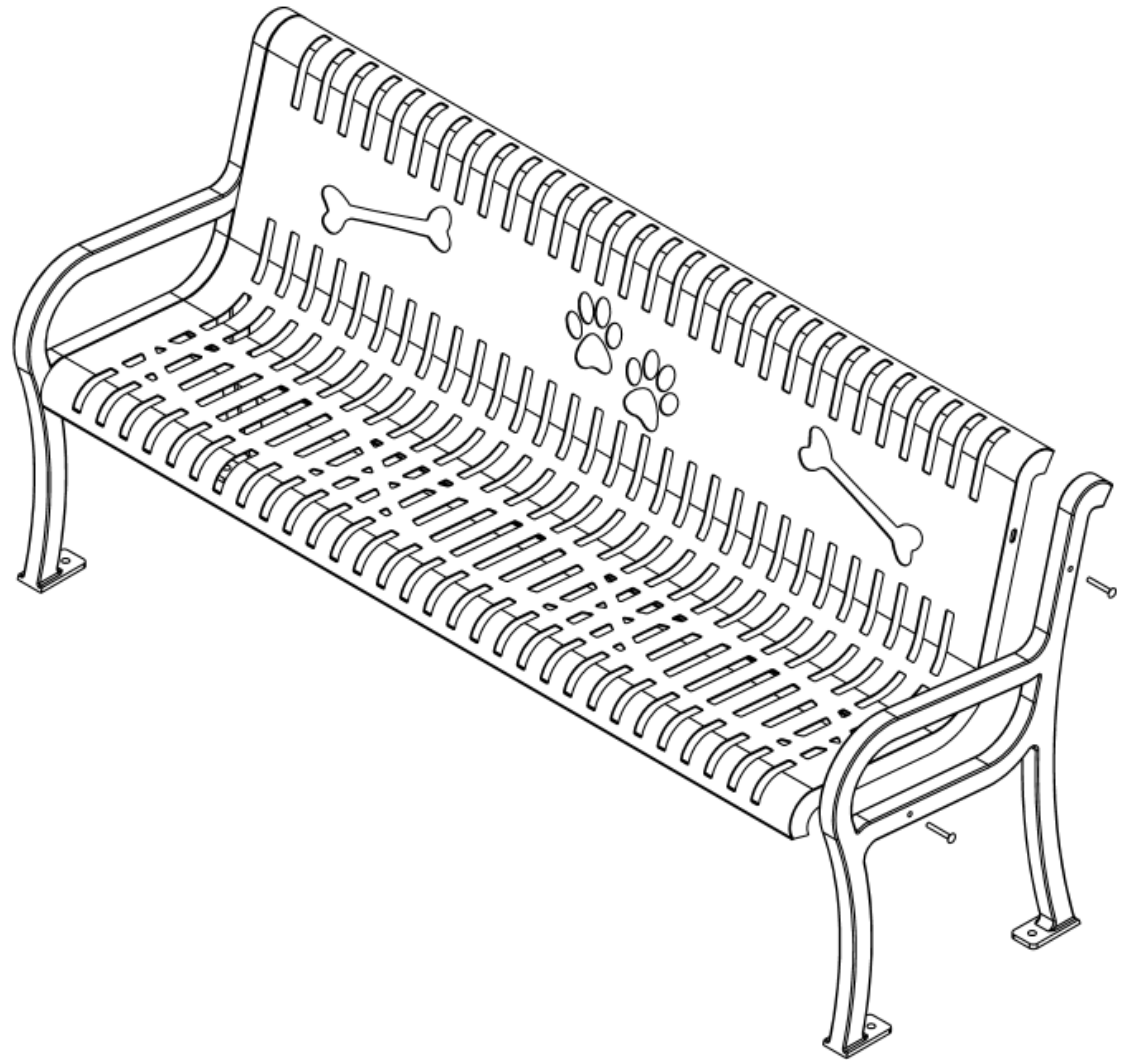

Attach the endframes to the bench seat using the specified hardware.

OVERALL DIMENSIONS

